

# UTC

## THE UNIVERSITY OF TENNESSEE CHATTANOOGA SITE DESIGN GUIDELINES / CAMPUS IMPROVEMENTS



ROSS/FOWLER

# University of Tennessee Chattanooga

Dr. William Stacy Chancellor  
 Richard Brown Vice Chancellor for Business and Operations

## Campus Landscape Committee

Linda Collins, Chair Associate Professor, Biological and Environmental Sciences  
 Dr. Margaret Kelley Vice Chancellor for University Advancement  
 Tom Ellis Assistant Vice Chancellor for Operations  
 Janet Spraker Assistant Director, Engineering Services  
 Cindee Pulliam Parking Services Manager  
 Doug Silver Associate Director, Facilities  
 Dr. Deborah Arfken Dean, Graduate School  
 Marc Booker Director, Student Housing  
 Julia Cronin Chair, Employee Relations Committee  
 Chris Charland Facilities Planning & Management  
 Connie Ratchford Facilities Planning & Management  
 Alan White Art Department Head  
 Dr. Claire McCullough Associate Professor, Engineering and Computer Science  
 Bryan Patten UC Foundation  
 Kino Becton President, Student Government Association  
 Ann Schimpf UTC Alumna  
 Cynthia Watson Fort Wood Community representative

## Ross/Fowler

Michael Fowler, ASLA  
 David Payne, ASLA  
 Stephen Hackney  
 Trish Harrison  
 Shauna Godlevsky  
 Sean Martin

## CONTENTS

Part 1	Introduction	1
Part 2	Goals & Objectives	1
Part 3	Site Assessment	2

## SITE DESIGN GUIDELINES

Part 4	Roadways	3
Part 5	Parking Lots	4
Part 6	Walkways/Plazas	5-6
Part 7	Entry Features	7
Part 8	Lighting	8-9
Part 9	Signage	10
Part 10	Site Furniture	11-12
Part 11	Site Improvements	13
Part 12	Utilities	14
Part 13	Screening	14
Part 14	Walls / Pilasters	14
Part 15	Landscape Maintenance	15-16
Part 16	Landscape Improvements	17-18
Part 17	Sculptures/Memorials	19

## CAMPUS SITE IMPROVEMENTS

Part 18	Priority Projects	20
Part 19	Pedestrian Mall	21
Part 20	Vine Street Improvements	22
Part 21	Oak Street Improvements	23
Part 22	Campus Gateways	24
Part 23	Greenway Access Points	25
Part 24	Summary Recommendations	26

(REVISED 3/26/08)

SBC# 540/05-02-01

Part 1: Introduction

1.01 The University of Tennessee Chattanooga is focused on the goal of creating clearly identified landscape and site standards for the beautification of campus as well as the establishment of long range priorities and needs for future landscape and hardscape projects. This document is a product of the careful evaluation of user input and the recently completed Campus Master Plan.

1.02 These design guidelines are intended as a guide for future Site and Landscape improvements at the University of Tennessee Chattanooga. Currently, the campus lacks continuity of site and landscape character which is essential to a successful college campus. The concepts and guidelines presented in this booklet have evolved from careful analysis of the site and the surrounding urban fabric.

Part 2: Goals & Objectives

2.01 The purpose of these design guidelines is to create a stronger visual identity for the campus environment by addressing the following issues:

- A. Strengthen campus identity and sense of place.
- B. Enhance campus character for use as a recruiting and retention tool.
- C. Improve campus circulation.
- D. Reinforce pedestrian oriented campus.
- E. Minimize vehicular and pedestrian conflicts.
- F. Enhance accessibility for disabled campus community.
- G. Develop a cohesive and unified character which respects the history of the campus.
- H. Target new improvements to strengthen and unify the visual character of the campus.
- I. Create a strong pedestrian / academic core with vehicular circulation along the perimeter.
- J. Address commuter / parking issues.

2.02 Ross/Fowler has also identified several initial projects which are felt best to begin a campus nucleus.

- A. Improvement of the campus gateways and identification markers.
- B. Enhance the Vine and Oak Streetscapes to make them pedestrian friendly.
- C. Create a strong pedestrian connection between McCallie Avenue and East 5<sup>th</sup> Street.



Part 3: Site Assessment

3.01 Ross/Fowler visited the campus and conducted on site inventories and assessments of the existing campus environment. As a result of this site assessment, we have the following comments.

- A. The campus has no defined edges.
- B. The existing short term and high maintenance plantings should be eliminated.
- C. The existing pedestrian lights are dated and should be replaced.
- D. Pedestrians / vehicular / bicycle conflicts are not well resolved.
- E. Pedestrian flow through campus needs to be reinforced.
- F. On campus views need to be enhanced.
- G. Future greenway through campus needs to be incorporated with a possibility of natural areas.
- H. Parking areas need to be better integrated with the pedestrian character of the campus.
- I. Pedestrian connections to existing and new housing need to be strengthened.
- J. The existing mature tree stock is limited and should be enhanced by the addition of more long lived tree stock.
- K. All major areas of campus should be accessible to the handicapped.
- L. The speed of traffic on campus should be calmed and reduced through the use of standard calming techniques.
- M. The large quantity of conflicting and dissimilar elements on campus result in visual clutter, which should be reduced.

3.02 Existing campus character to be retained:

- A. Tree lined streets.
- B. Brick and stone elements.
- C. Open lawn areas.
- D. Specimen tree stock.
- E. On street parking.
- F. Pedestrian nature of campus.
- G. Green campus.
- H. Limestone walls

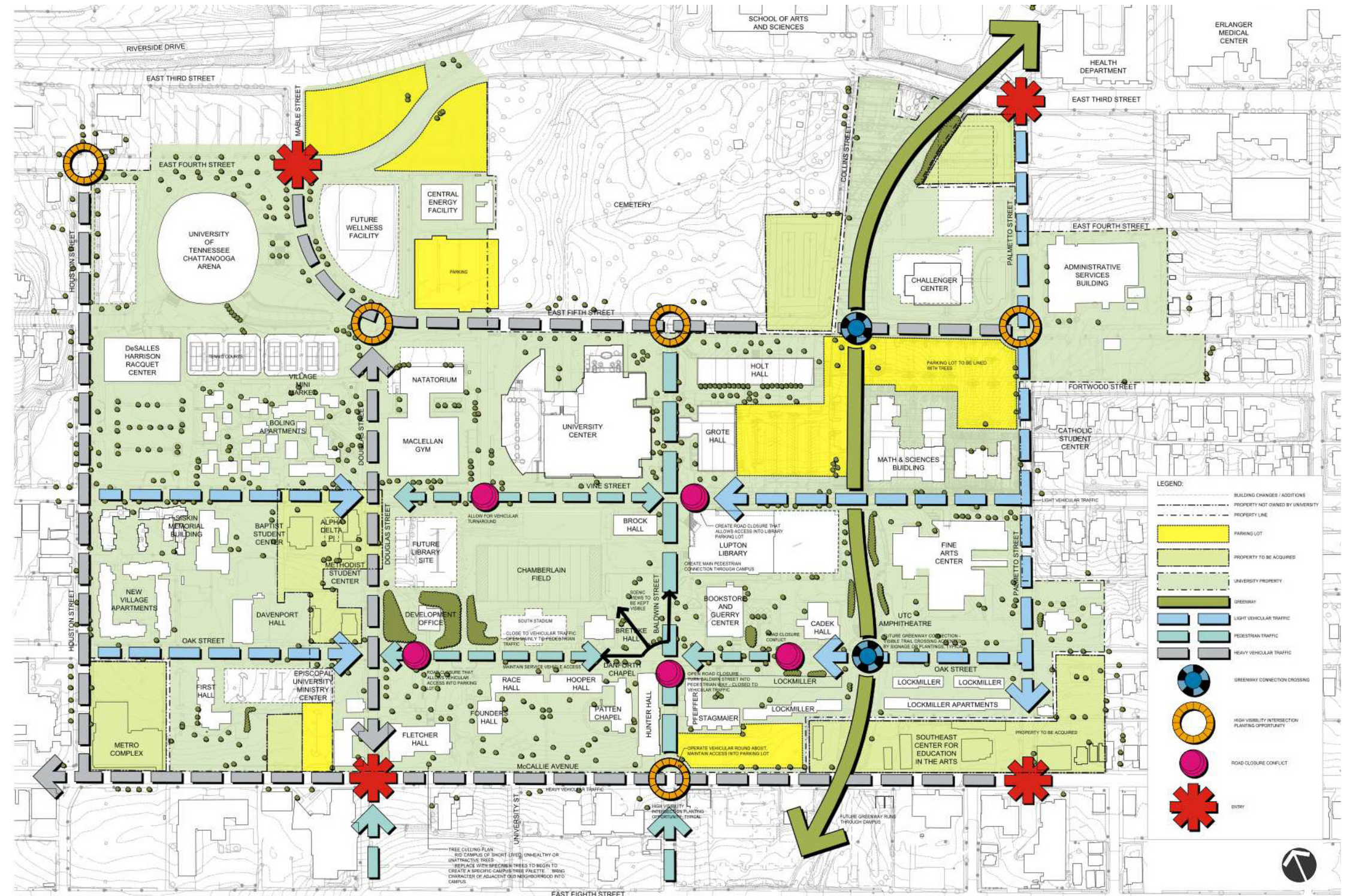

Part 4: Roadways

4.01 The campus road network shall be designed to calm the speed of traffic and to facilitate safe pedestrian movement. The roadways shall be in conformance with the following standards.

- A. Landscape areas shall be incorporated within the parallel parking zone and shall be referred to as 'bump outs'.
  - 1. Bump outs shall be a minimum size of 8' x 8' and shall be bordered by a curb / gutter which meets city of Chattanooga standards.
  - 2. Bump outs shall be planted with a minimum of one tree.
  - 3. Where appropriate, bump outs may serve as the pedestrian crossing point.
- B. Street trees shall be planted along the periphery of the street at a minimum ratio of 1 tree per 35' of roadway frontage (as required by the Landscape Ordinance Manual prepared by the Chattanooga Hamilton County Regional Planning Agency).
- C. The Washington ContraCline light fixture shall be incorporated into the design to replace existing light fixtures.

4.02 It is recommended the the University proceed forward with an approach which involves both the Chancellor working with the Mayor on the administrative level and the Landscape Committee / Facilities Planning working with the design professionals of the Planning and Design Center to forward the importance of these improvements through words and plan proposals. Further, it is recommended that the University take a pro-active role in the upcoming downtown Master Plan process.

4.03 5<sup>th</sup> Street

5<sup>th</sup> street is a major arterial for traffic movement onto campus. There is currently parallel parking on both sides of the street. Due to the limitations of the road right of way and utility conflicts it is recommended that bump outs be incorporated to emphasize the continuity of the streetscape. These recommendations work with and maintain the existing power lines.

4.04 Vine / Oak Streets

Vine and Oak street are internal campus streets with parallel parking on both sides. Due to their proximity to the center of campus, it is recommended that they receive streetscape improvements to both define parallel parking and to help facilitate safe pedestrian movement. Further, it is recommended that Vine & Oak street remain closed to through traffic with a removable access system.

4.05 Houston / Douglas / Palmetto Streets

Houston, Douglas and Palmetto street are campus perimeter streets with associated parallel parking on one side. Landscape enhancements shall be incorporated to enhance both pedestrian and vehicular movement.

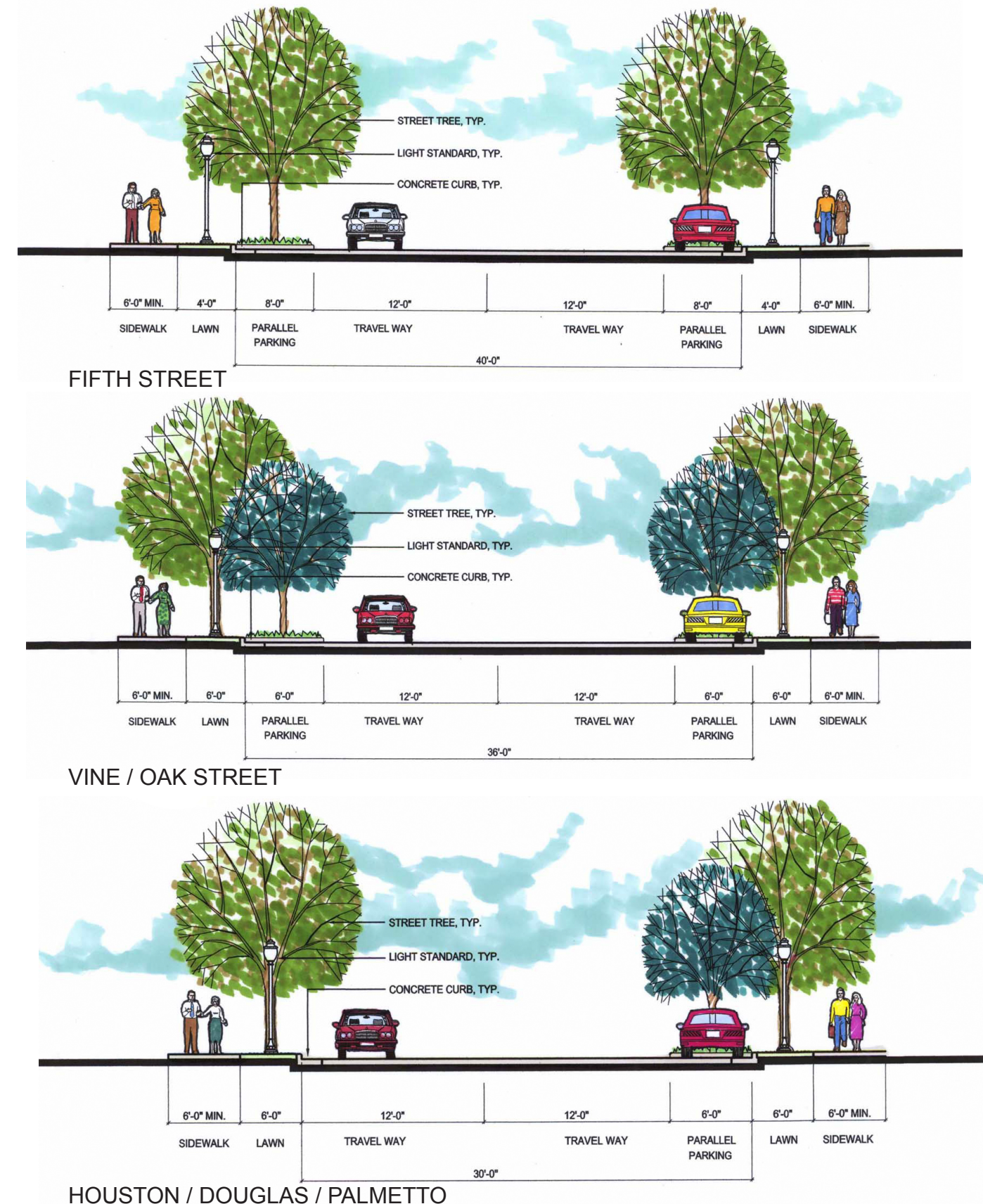

Part 5: Parking Lots

5.01 Parking lots shall be designed to reduce the amount of paved area while enhancing the visual qualities of the campus. Pedestrian movement from the vehicle to the pedestrian network shall be strengthened. Parking lot design shall be designed in conformance with the following standards:

A. At a minimum, all parking lot design shall be in conformance with the Landscape Ordinance Manual as prepared by the Chattanooga / Hamilton County Regional Planning Agency.

Ordinance requires:

1. No parking space can be more than 60' from a tree.
2. All interior parking that contains a minimum of 10 spaces shall be bordered on both sides by a landscape island.
3. Ends of all perimeter parking bays shall be bordered by a landscape peninsula.
4. Landscape islands shall be minimum of eight feet wide and a minimum of 200 square feet in area.
5. Landscaped islands and peninsula shall be planted with at least one shade tree.
6. All landscaped islands and peninsulas shall be bordered by a curb or wheel stop.

B. In addition to these minimum requirements, all parking lots shall have the following:

1. Clearly defined pedestrian connections to existing pedestrian circulation.
2. Additional planting strips along interior parking space interlock to allow for additional shade tree plantings.
3. Lawn will be incorporated around the perimeter of the parking lot.

C. Parking lot shall be asphalt.

D. Parking lot shall be designed with a minimum slope gradient of 2% and a maximum slope gradient of 5% wherever possible.

E. Handicap Parking spaces shall be incorporated into the design and in accordance with local codes and the National ADA Standards.

F. Parking lots shall be illuminated with a minimum light intensity of 1.5 foot candles.

G. Parking lots shall be clearly indicated by use of campus standard signage.

H. Improvement priorities should be given to gravel and longterm perimeter parking lots.

I. Parking garage lighting shall be governed by local building code.

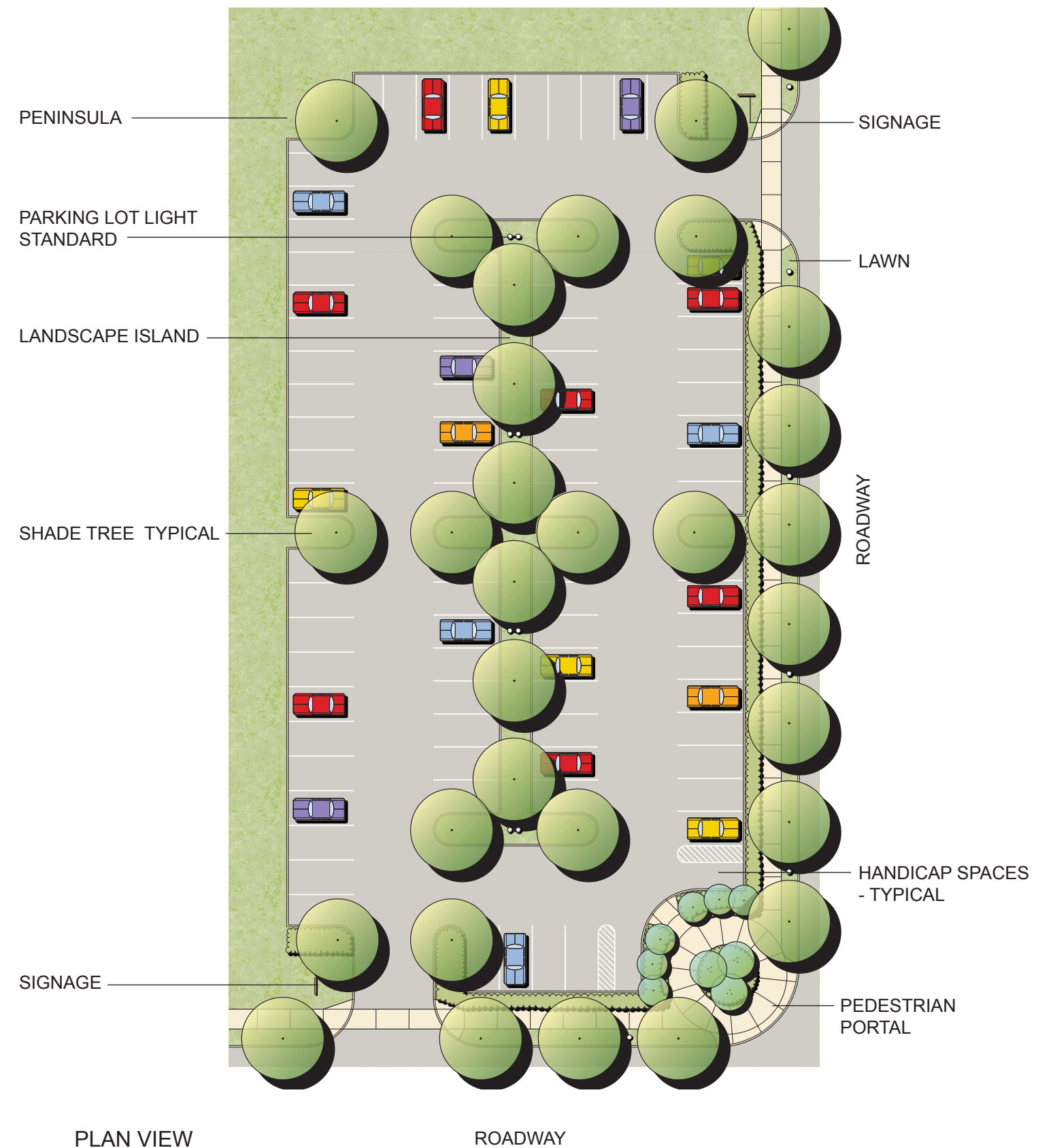

PLAN VIEW

ROADWAY

Part 6: Walkways and Plazas

Accent paving will be decided by a design professional, but will be reserved for high impact and important pedestrian gathering areas. Materials that are not ADA compliant shall not be used. Individual projects can be designed with different patterns.

6.01 Site improvements which require paving shall be in conformance with the following standards:

- A. Material: Concrete - Shall be the standard pedestrian walking material used throughout campus for all projects. (see Exhibit A)
  - 1. Concrete shall be 4" thick natural grey with reinforcing. All joints shall be 3/8".
  - 2. Edges and joints shall have 10" wide smooth trowel edges.
  - 3. Finish shall be a medium broom finish, perpendicular to the longitudinal axis.
  - 4. Score joints shall be 10' o.c. maximum.
  - 5. Expansion joints shall be 40' o.c. maximum and shall be constructed with smooth internal dowels at the joints to prevent vertical movement.
  - 6. All concrete paving shall be sloped to drain at 1% minimum.
    - Application - Sidewalks, plazas, accent paving, banding and parking lot accent pavers.
  
- B. Material: Brick (see Exhibit B)
  - 1. Brick paver system shall consist of a brick paver attached to a 4" thick reinforced concrete subbase with a 1" thick mortar bed. Herringbone, Running Bond, and Basketweave are all acceptable brick patterns.
  - 2. Brick paving shall be constructed with natural grey 3/8" tooled joints maximum.
  - 3. Expansion joints shall be 40' o.c. with an expandable joint compound with color to match joints.
  - 4. Brick paver color shall match surrounding architectural color and be approved by UTC.
  - 5. Brick pavers shall be a standard 4" x 8" rectilinear shape. Paver thickness shall be 2" minimum.
    - Application - Accent paving areas and banding.

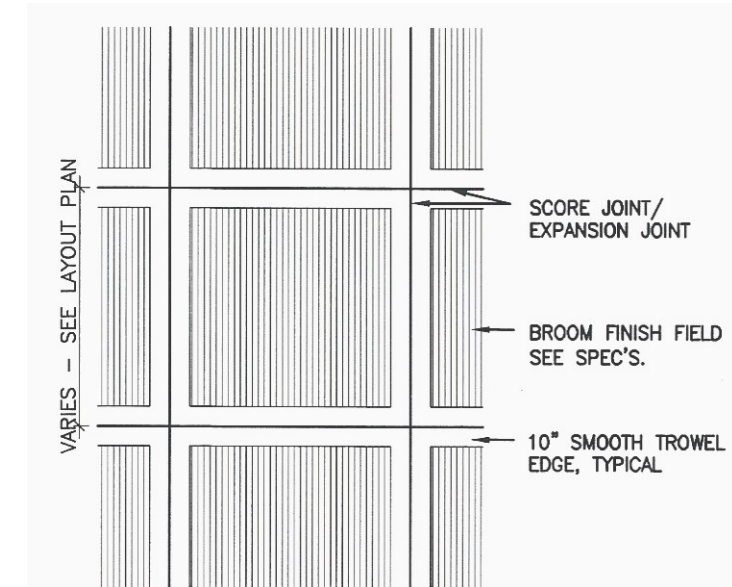

CONCRETE PAVING  
(Exhibit A)

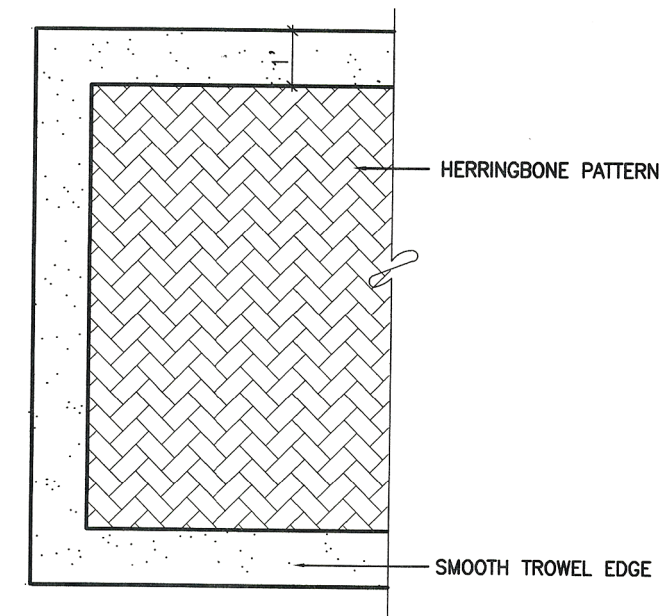

BRICK PAVING  
(Exhibit B)

6.01 Site improvements which require paving shall be in conformance with the following standards (Continued):

C. Material: Concrete Pavers (see Exhibit C)

1. Concrete paver system shall consist of a concrete paver attached to a 4" thick reinforced concrete subbase with a 1" thick mortar bed.
  2. The paver shall be minimum 2 3/8" thick.
  3. Paving pattern shall be Appian Stone with 5 1/2 x 5 1/2 sq. unit and a 5 1/2 x 8 1/4 rectangular unit available from Paver Systems
  4. Color shall be granite blend
  5. Unit pavers shall have 1/8" joints butted together.
- Application - Pedestrian accent paving areas and parking lot banding.

D. Material: Native stone pavers (see Exhibit D)

1. Stone Paver system shall consist of a native stone paver installed on a 4" thick reinforced concrete subbase.
  2. The stone paver shall be minimum 1 1/2" thick.
  3. Paving pattern shall be a random ashlar.
  4. Color - mix of dark and light grey.
  5. Stone sizes shall vary. Minimum size shall be 12" x 12". Maximum size shall be 24" x 36".
  6. Joints shall be 3/8" mortar joints. Color to be grey.
- Application - Banding, accent areas and plazas.

E. Materials: Banding

1. Banding shall consist of a 8" to 12" wide concrete, stone, unit paver or brick strip which separates and divides large expanses of paving.
  2. Banding shall be used to join two (2) dissimilar paving materials.
  3. Banding shall have 3/8" joints at 10' o.c. and expansion joints at 40' o.c.
- Application - Paved areas.

F. Stamped Concrete: Stamped or colored concrete are not recommended materials for use on campus. Stamped concrete shall be allowed within the City Right of Way.

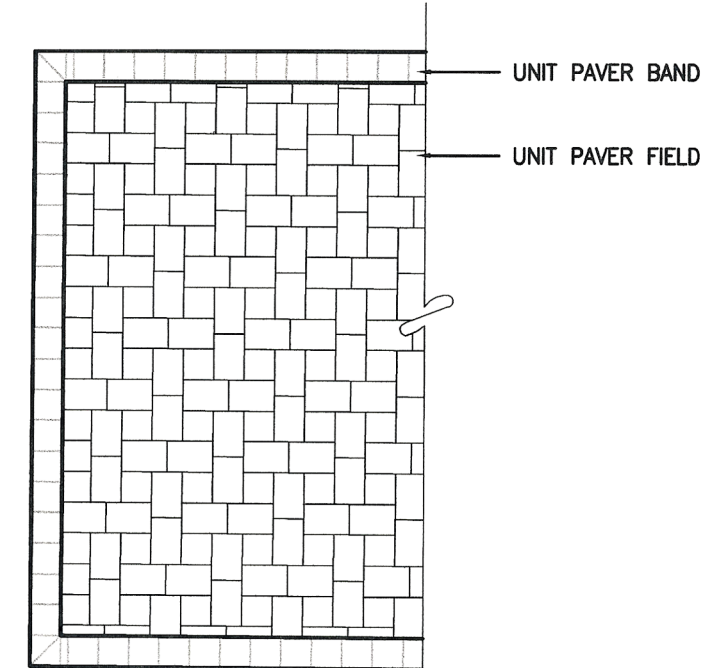

CONCRETE PAVERS - APPIAN PATTERN (Exhibit C)

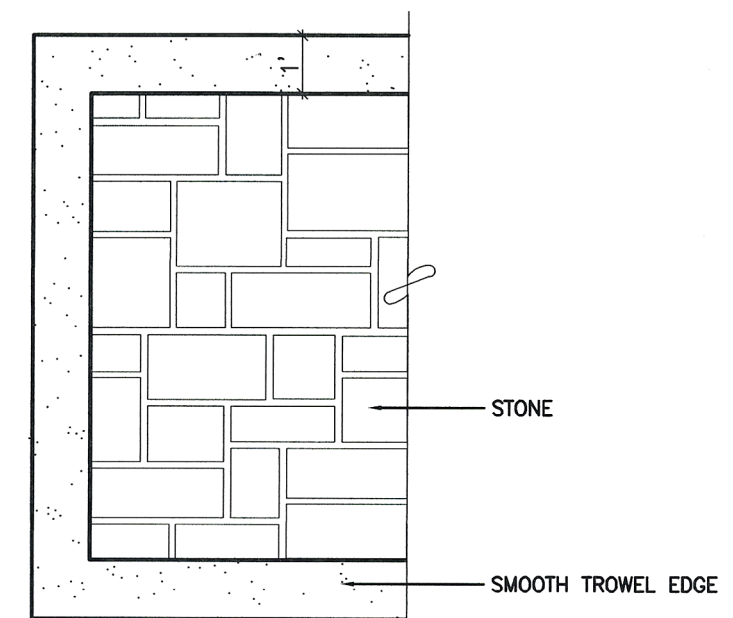

STONE PAVING - RANDOM ASHLER PATTERN (Exhibit D)





Part 8: Lighting

8.01 Lighting site improvements shall conform to the following standards:

- A. Architectural accent lighting –  
 Ingrade architectural light fixture  
 Manufacturer: Hydrel  
 Model number: 9100 series – wall wash  
 Lamp type: metal halide  
 Application: Up light walls, signs, trees and sculpture  
 Direct Contact #: (818)362-9465
- B. Vandal resistant bollard –  
 Manufacturer: KIM Lighting  
 Model number: VRB1-100MH208-BL-P  
 Finish: black  
 Application: Pathways or pedestrian locations  
 Direct Contact #: (818)968-5666
- C. Pedestrian pole light fixture (see Exhibit C) –  
 Washington or pedestrian Globe ContraCline with Chicago series cast aluminum decorative pole mounted on a concrete base.  
 Manufacturer: Moldcast  
 Pedestrian Contra-Cline Model number: PCC-PM-175MH-BLK with 14' Post: 14' tall w/ 12" dia. base, Model number: DB14F14-188; Post Manufacturer: Architectural Area Lighting  
 Color: black  
 Lamp type: Metal halide  
 Direct Contact #: (510)562-3500  
 Washington Contra-Cline Model number: WCC-PM-175MH-BLK with 16' Post to be used on Baldwin Pedestrian Spine
- D. Parking lot lighting (see Exhibit D) –  
 Cut off series pole light with round aluminum pole.  
 Manufacturer: KIM Lighting  
 Product number: CCS series arm mount model  
 Color: black.  
 Height: 25'  
 Lamp type: Metal halide  
 Direct Contact #: (818)968-5666



LIGHT FIXTURE (EXHIBIT C)



LIGHT FIXTURE (EXHIBIT D)



LIGHT FIXTURE (EXHIBIT A)

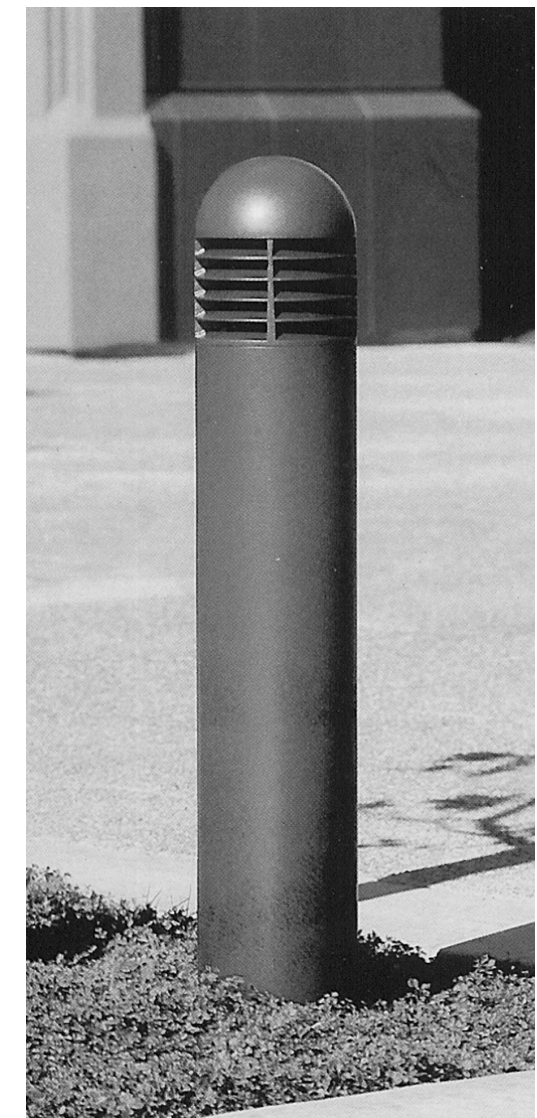

LIGHT FIXTURE (EXHIBIT B)

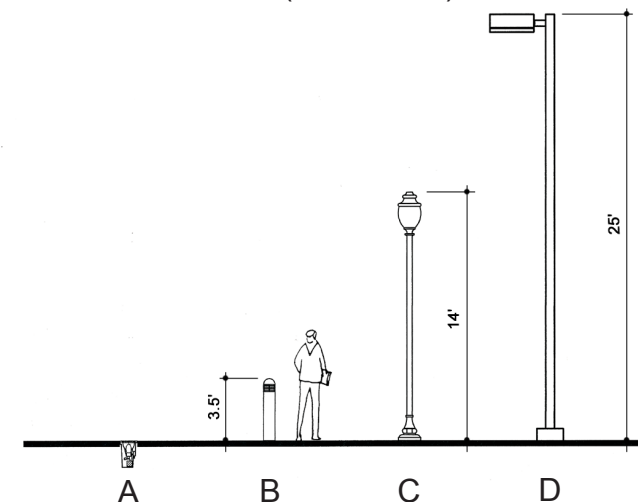

## Part 8: Lighting

- E. Wall lights –
  - Low Level Flood Light
  - Manufacturer: Kim Lighting
  - Model number: LLF
  - Color: Grey or black depending on application.
  - Lamp type: Metal Halide
  - Application: Steps or walls
  - Direct Contact #: (818)968-5666
  
- F. Architectural lighting –
  - Manufacturer: Kim Lighting
  - Model number: AFL10 Series
  - Color: Black
  - Lamp type: metal halide
  - Application: Buildings, walls, sculptures
  - Direct Contact #: (626)968-5666
  
- G. Concrete Footings for pole lights at paving, finish grade, and slope conditions (see Exhibit G)



LIGHT FIXTURE (EXHIBIT E)



ARCHITECTURAL LIGHTING (EXHIBIT F)

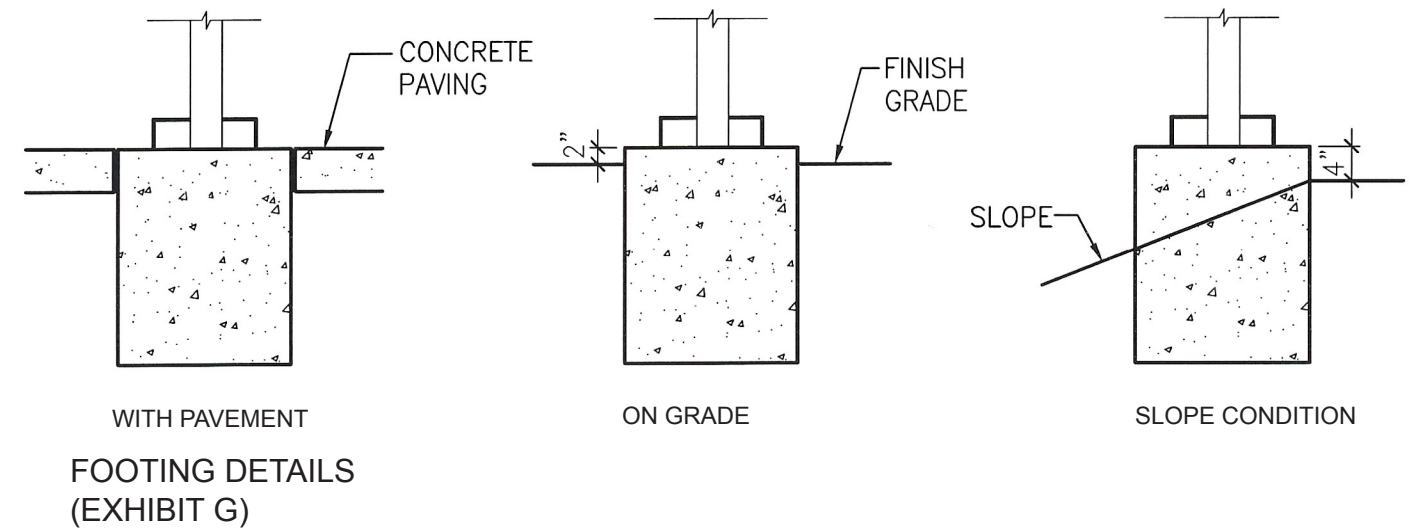

WITH PAVEMENT  
ON GRADE  
SLOPE CONDITION  
FOOTING DETAILS (EXHIBIT G)

Part 9: Signage

9.01 Wayfinding signage shall be designed to assist both vehicular and pedestrian traffic to locate on-campus destinations. The vehicular and pedestrian directional, as well as the parking lot and building identification signage, shall be of free standing and uniform elements. Locations of signage shall be consistently positioned in front of buildings, adjacent to parking lots or in predictable locations established for the visitor to focus on. Campus signage shall conform to the following standards:

- A. All signs shall be metal panel and square metal support posts.
- B. The new signage format shall be white lettering on a black background. As recognition of school colors, the university logo may be incorporated into the design. By proposing a black back ground with white lettering, the dark sign blends into the landscape making it less obtrusive and white lettering on a dark background is more legible.
- C. Regulatory signage on campus shall be designed as a metal panel on a square black post.
- D. Sign font shall be 'Goudy'.
- E. All signs shall be freestanding, panel and post as indicated.

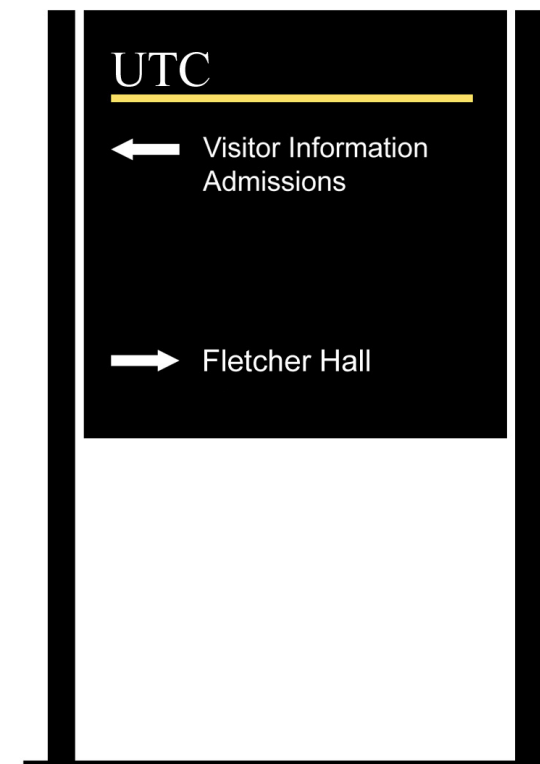

PROPOSED SIGN

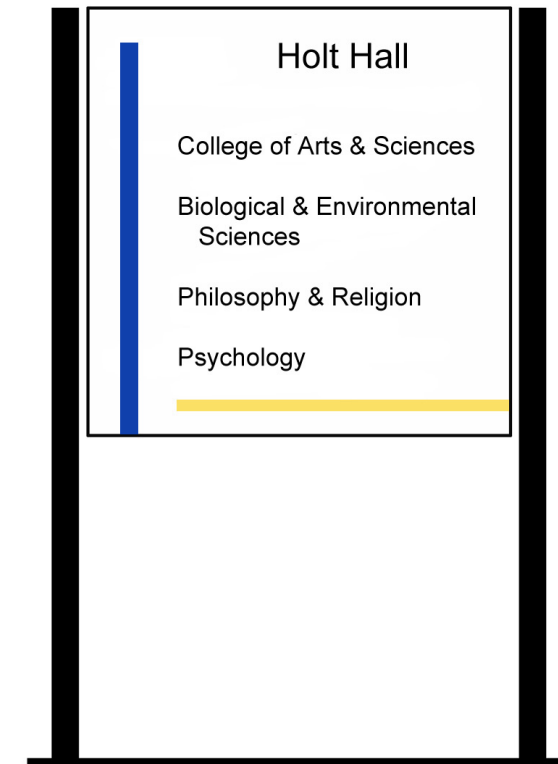

EXISTING SIGN

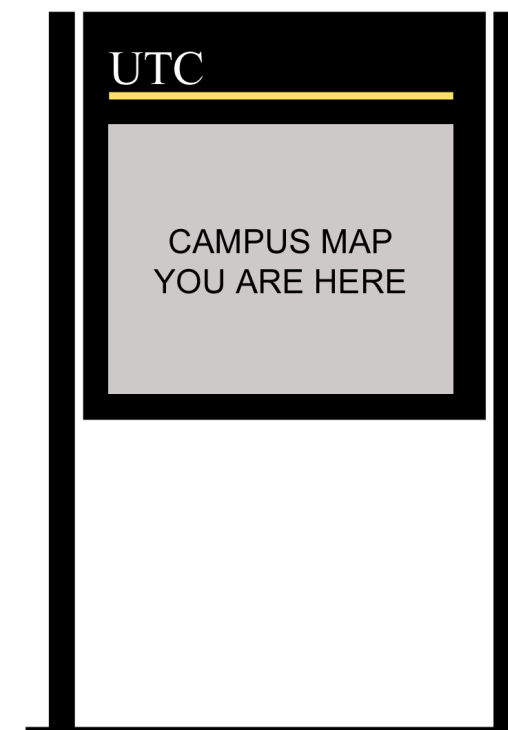

YOU ARE HERE SIGN

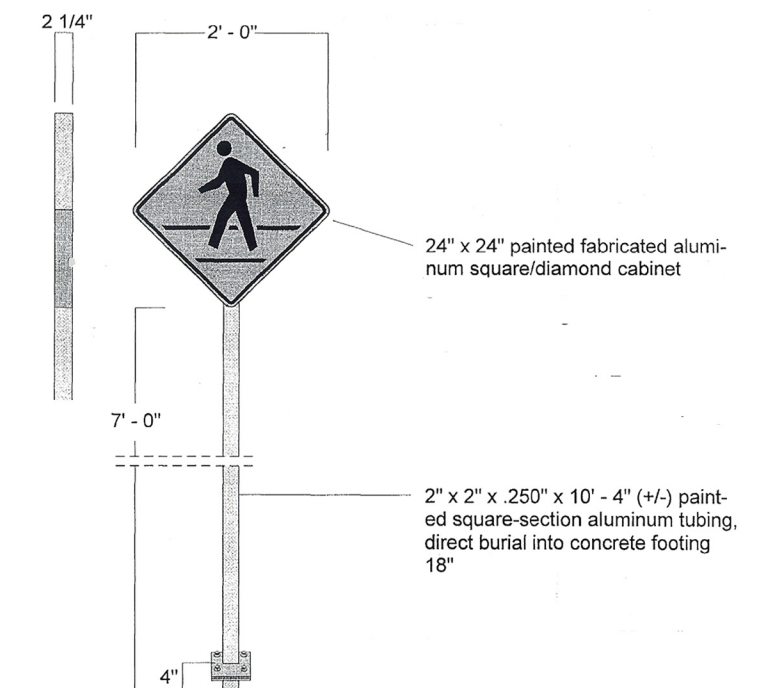

REGULATORY SIGN

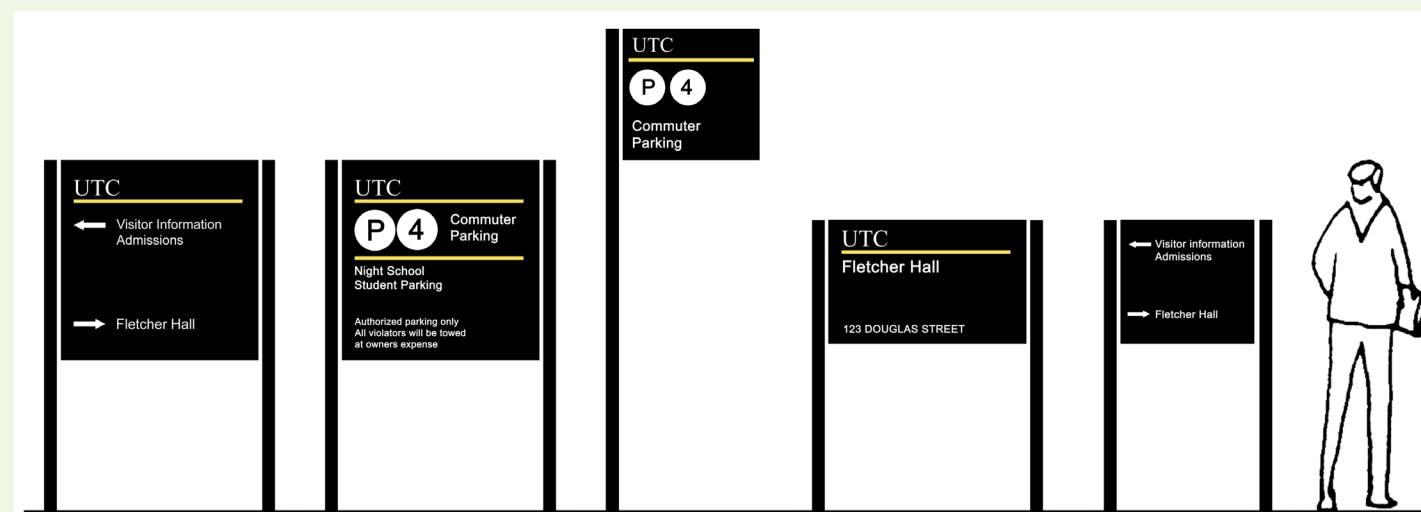

VEHICULAR DIRECTIONAL

PARKING LOT IDENTIFICATIONS

BUILDING / GROUND IDENTIFICATION

PEDESTRIAN DIRECTIONAL (YOU ARE HERE)

Part 10: Site Furniture

10.01 As projects are developed on campus and as existing inventory needs be replaced, the following site furniture has been chosen as the approved standard:

- A. Bike racks (see Exhibit A):  
Bicycle Rack  
Manufacturer: Timberform/Columbia Cascade or equivalent  
Product number: Cycloops #2170  
Color: black  
Direct Contact #: (800)547-1940
  
- B. Table sets (see Exhibit B):  
Timberform Renaissance round table with center support and direct embedment  
Product number: 2912-0042-E  
Timberform Renaissance seat w/ back  
Product number: 2911-20  
Manufacturer: Columbia Cascade  
Color: black  
Direct Contact #: (800)547-1940
  
- C. Benches (see Exhibit C):  
Timberform Renaissance bench with armrests  
Manufacturer: Columbia Cascade  
Product number: 2806-6  
Color: black  
Contact #: (800)547-1940
  
- D. Seats (see Exhibit D):  
Timberform Renaissance seat with armrests  
Manufacturer: Columbia Cascade  
Product number: 2802-6  
Color: black  
Contact #: (800)547-1940

- E. Litter receptacles (see Exhibit E):  
Timberform Renaissance litter receptacle with flat top lid and direct embedment  
Manufacturer: Columbia Cascade  
Product number: 2811-FT-E (23 Gal)  
2817-FT-E (32 Gal)  
Color: black  
Direct Contact #: (800)547-1940

Note:

- Method of attachment shall be either of the following:
1. Direct embedment with footing sized per manufacturer's recommendations.
  2. Attached to pavement with expansion anchor per manufacturer's recommendations.



BIKE RACK (EXHIBIT A)



BENCH (EXHIBIT C)

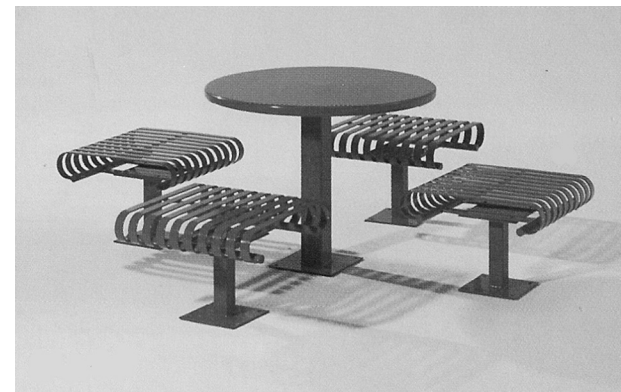

TABLE SET (EXHIBIT B)



SEAT (EXHIBIT D)



LITTER RECEPTACLE (EXHIBIT E)

Part 10: Site Furniture

F. Ash receptacle (see Exhibit F):  
 Pole mounted classic Butler  
 Manufacturer: Site Form  
 Color: black  
 Direct Contact #: (800)451-0410

G. Traffic/Pedestrian bollard (see Exhibit G):  
 Chicago Series cast aluminum bollard  
 with eye bolt  
 Manufacturer: Antique Street Lamps, Inc.  
 Model number: BCA BCH12DT ANBK  
 EBB  
 Color: black  
 Direct Contact #: (512)977-84444

H. Traffic/Pedestrian bollards shall be connected together with heavy duty galvanized metal chains with pad locks to allow service and emergency vehicle access (see Exhibit H).  
 Manufacturer: Antique Street Lamps, Inc.  
 Model number: BCA BCH12DT ANBK  
 EBB  
 Color: black  
 Direct Contact #: (512)977-84444

I. Cast Stone planters (see Exhibit I):  
 International Collection  
 Manufacturer: Longshadow  
 Color: Natural  
 Direct Contact #: (618)893-4831  
 www.longshadow.com

J. Bar Gate (See Exhibit J)

K. Emergency telephones:  
 Paint existing poles black

L. Mailboxes:  
 USPS should be consulted for the design and location of mailboxes.



ASH RECEPTACLE (EXHIBIT F)

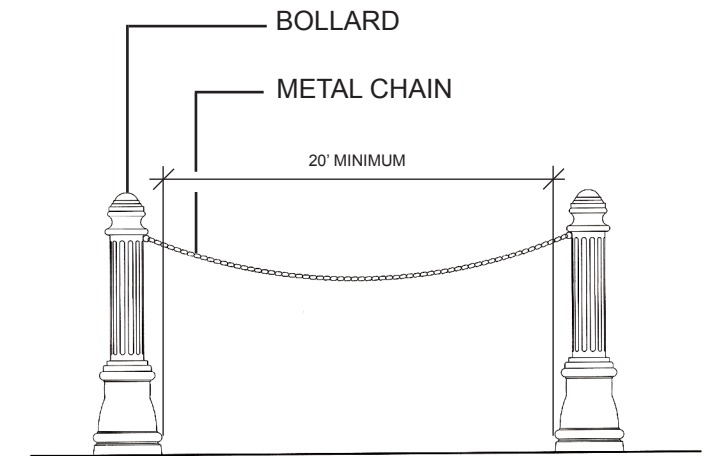

REMOVABLE ACCESS SYSTEM (EXHIBIT H)

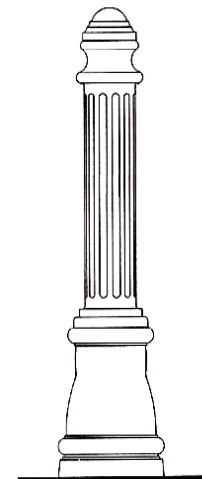

TRAFFIC/PEDESTRIAN BOLLARD (EXHIBIT G)



CONCRETE PLANTERS (EXHIBIT I)

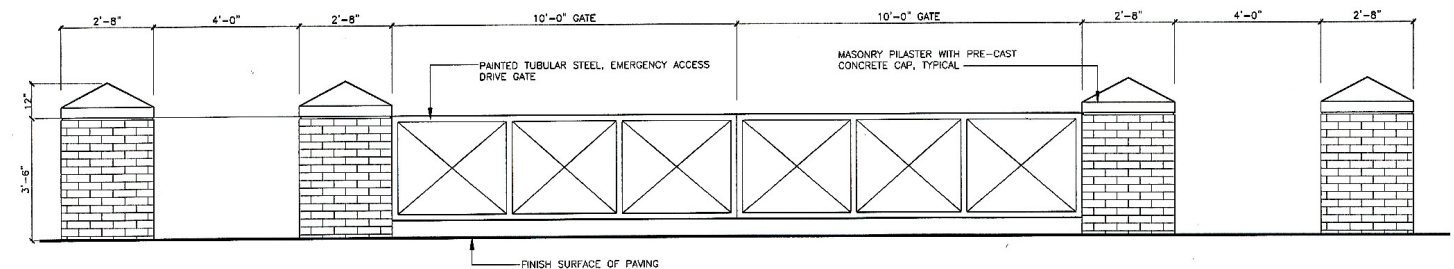

BAR GATE (EXHIBIT J)

SITE DESIGN GUIDELINES

Part 11: Site Improvements

A. Fences (see Exhibit A):

1. Where required to reinforce the boundary of the campus.
2. Design:
  - A. Height (4'-6')
  - B. Simple timeless design in character with campus.
  - C. 1/2" vertical pickets at 4" max. o.c.
  - D. Posts – size: 2" x 2" at 5' O.C., evenly spaced.
  - E. Rails top and bottom – size: 2" x 2".
3. Material: Metal – painted.
4. Color: black
5. In low pedestrian traffic situation a manufactured fencing system will be allowed, provided it visually matches tubular steel fence design.

B. Guardrails (see Exhibit B):

1. Where required due to elevation changes adjacent to pedestrian ways.
2. Design:
  - A. Height (42").
  - B. Simple timeless design in character with campus.
  - C. 1/2" vertical pickets at 4" max. o.c.
  - D. Posts – size: 2" x 2" at 5' O.C., evenly spaced.
  - E. Rails top and bottom – size: 2" x 2".
3. Material: Metal – painted.
4. Color: black

C. Handrails (see Exhibit C):

1. Application: Where required at steps and ramps.
2. Design:
  - A. Height (34").
  - B. Simple timeless design in character with campus.
  - C. Posts – size: 1 1/2" Dia. at 5' O.C., evenly spaced.
  - D. Rails top and bottom – size: 1 1/2" Dia.
3. Material: Painted steel.
4. Color: black

D. Pre-cast concrete / limestone cap seatwall (see Exhibit D)

E. Shuttle / Bus Shelters:

Shelters shall be designed by the City of Chattanooga. Coordinate bus / shuttle shelters with Carta. Color of shelters need to be black so it will relate to campus.

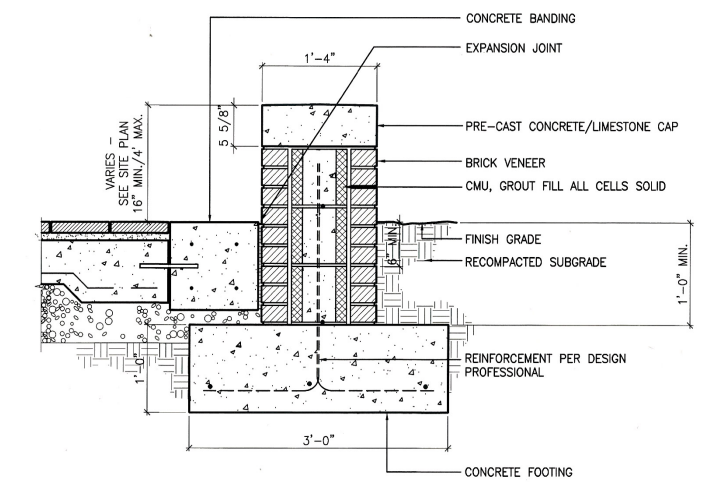
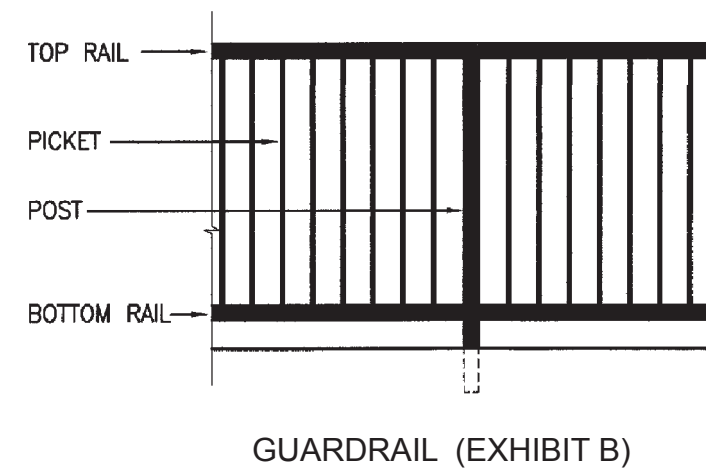
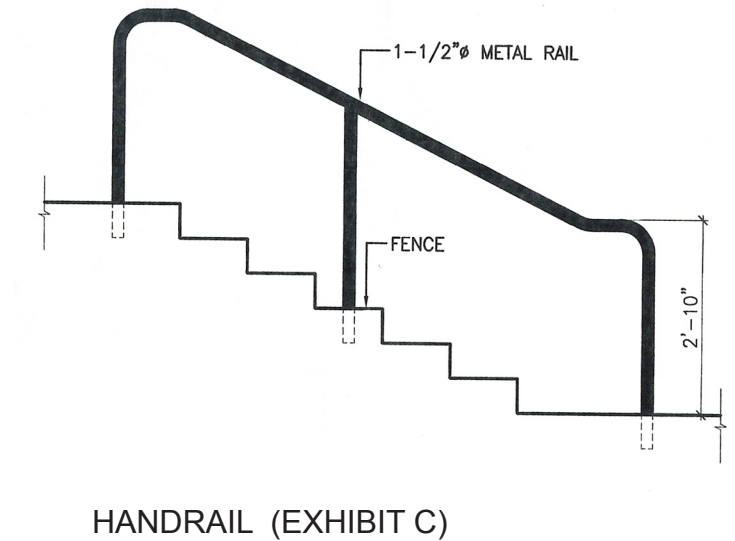
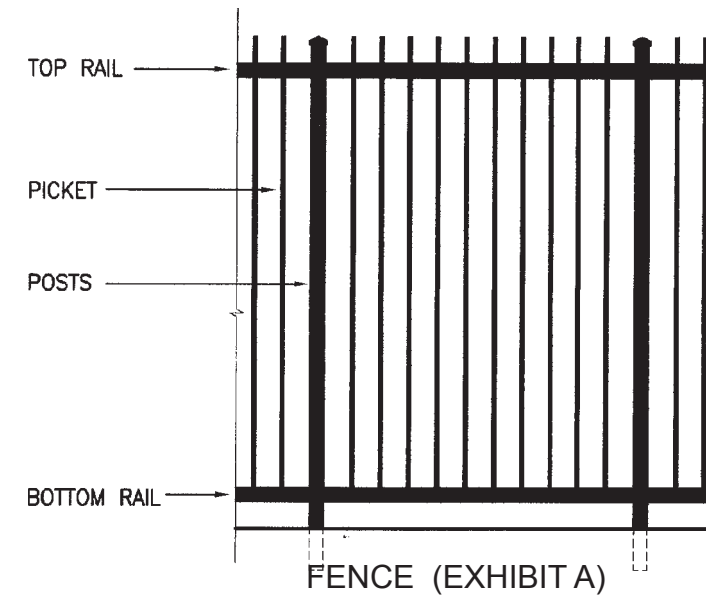

PRE-CAST CONCRETE / LIMESTONE CAP SEAT WALL (EXHIBIT D)

Part 12: Utilities

12.01 The existing campus condition contains a large amount of overhead utilities. This condition adds to the visual clutter and has resulted in the severe pruning damage to the existing heritage tree stock. As a result, it is recommended that overhead utility lines be buried underground where possible.

Part 13: Screening

13.01 The need for screening of campus utilities and service areas has been identified. Screening of these areas shall conform to the following standards:

- A. Where there is sufficient space available, evergreen screen shall be utilized. Evergreen screen material shall be of a mature size capable of providing immediate screening.
- B. Where space is more restrictive, or where required to fit architectural character, screen walls made of brick with pre-cast concrete or stone caps shall be utilized.
- C. Where space is restrictive and it is not possible to screen with architectural walls or landscaping, then a metal screen enclosure shall be used.
  - 1. Walls: 4" x 4" tubular steel posts with caps and 1" x 2" top and bottom rails, which support painted aluminum, ribbed panels.
  - 2. Gates: 2" x 2" tubular steel verticals with 1" x 2" tubular steel horizontal members and 3/4" square tubular steel pickets at 4" o.c. The gate has a fine wire mesh backing, a key lock and heavy duty hinges.
  - 3. Color: black

Part 14: Walls / Pilasters

14.01 Site improvements which include walls and pilasters shall conform to the following standards:

- A. Walls shall be brick or stone to match the existing architecture.
- B. All walls and pilasters shall have brick, stone or pre-cast caps.
- C. Walls shall emulate character of existing wall vernacular - see exhibit / figure.
- D. Walls and pilasters shall be designed to relate to the pedestrian scale of the campus.
- E. Seat walls shall be used in high pedestrian circulation/concentration areas to aid pedestrian flow.
- F. Existing limestone walls are an important campus feature and shall be protected. When removal of limestone walls are required by new construction, they shall be replaced in kind



PLANT SCREEN



METAL SCREEN WITH GATE



BRICK SITE WALL



STONE SITE WALL



**Part 15: Landscape Maintenance**

Due to the scale and complexity of the campus landscape, a licensed Landscape Architect and other associated landscape professionals shall be retained and consulted for recommendations on all landscape maintenance projects.

15.01 Trees:

- A. A qualified arborist needs to be consulted regarding long term protection of these tree species including providing detailed recommendations for pest control, watering, fertilizing, pruning practice.
- B. Dead wood and limbs weak branches need to be removed.
- C. A program of deep watering and fertilization for each specific tree location needs to be developed and implemented. A program of appropriate care shall be developed for care of heritage trees by arborist.
- D. Work / Disturbance with in the drip line shall be avoided or minimized.
- E. A specimen tree replacement program needs to be developed to protect the existing campus tree inventory as it ages.
- F. As high maintenance and trees such as Bradford Pears decline or become damaged, they need to be replaced with long lived legacy lawn or street trees.
- G. Remove severely disfigured trees due to power lines.
- H. Landscape Maintenance operations are to be performed at such times of the year as appropriate to each respective task. Perform maintenance operations only during periods when weather conditions are suitable.
- I. It shall be the University's goal to plant or retain the specimen, long-lived trees and the creation of large open lawn areas.
- J. Small scale/ flowering trees shall be used in the following conditions.
  - 1. To emphasize building entries.
  - 2. To accent pedestrian intersections and plazas.
  - 3. To provide under story scale for specimen shade trees.
  - 4. Where overhead power lines are encountered which prevent planting of larger scale trees, small scale / flowering trees shall be utilized.
- K. Lawn and Street tree planting shall conform to the following uses.
  - 1. Single specimen tree species should be established consistently along each street.
  - 2. Trees shall be planted based upon longevity, ease of maintenance and appropriateness for the condition.
  - 3. A landscape architect will be required for spacing and location of trees.
- L. Evergreen and screen trees shall conform to the following uses:
  - 1. To accentuate architecture and provide year round interest.
  - 2. Evergreen trees shall be interspersed with lawn trees to enhance the landscape.
  - 3. Evergreen trees shall also be used to provide year round visual screening.
  - 4. Evergreen trees shall be used to provide buffering between incompatible uses.

15.02 Shrubs

- A. Shrub planting needs to be kept to a minimum and should be reserved for the following functional use.
  - 1. Define entrances to building.
  - 2. Used as screening
  - 3. Pedestrian directional masses.
  - 4. Accent / emphasize entry well and entries to campus.
  - 5. Used as a background.
- B. Shrub species shall be selected which do not require periodic pruning.

15.03 Ground Covers

Ground covers shall conform to the following uses:

- A. Use of groundcovers shall be minimized for ease of maintenance.
- B. Ground covers shall be used on steep slopes where use of mower lawn is impractical of unsafe, such as slopes, which exceed 3:1 (30%).
- C. Groundcovers shall be utilized in high shade locations where lawn can not be established.
- D. Groundcovers may also be used where space is limited and it is unpractical to maintain turf.

15.04 Turf

- A. A turf maintenance plan needs to be developed which addresses the mowing, fertilizing and aeration of the existing and proposed turf areas.
- B. Turf mowing shall be performed from March 1 to November 15 at a frequency such that no more than one-third of the leaf area is removed at any one time. Mow no less than once every seven (7) days from April 1 to September 1. Mow as needed during the remainder of the season but no less than once every ten (10) days. Maintain lawn at 2 1/2" to 3" in height.

15.05 Mulch

- A. Replenish shredded hardwood mulch twice annually to maintain a proper depth of 3-4" in all mulched areas including tree rings. Re-mulching operations should take place immediately following an annual winter or early spring clean up of all bed areas. A second re-mulching should take place in the period of transition from late summer to early fall.
- B. Treat all mulched areas with a pre-emergence weed-chemical every 3-4 months.
- C. Maintain clean smooth curvilinear bed edges where beds meet lawns with an edge.

15.06 Irrigation Systems

- A. Perform sprinkler irrigation system maintenance and watering operations as appropriate and in accordance with seasonal and climatic requirements.
- B. Winterize irrigation systems before frost in the fall to prevent damage to irrigation system components and activate irrigation systems in the spring after danger of frost is past to provide optimum spring growth.

### 15.06 Seasonal Color Beds:

Due to the high maintenance costs associated with seasonal color beds, their use shall be limited to high impact areas only. Those areas will include concentrated pedestrian and vehicular use areas as identified on the color bed location plan.

The installation of seasonal color beds shall be in conformance with the following standards:

- A. The seasonal color shall be rotated three times per year:
  1. Late spring / early summer planting may include summer annuals such as begonias, marigolds, and impatiens.
  2. Late summer / early fall planting shall include mums.
  3. Fall planting shall include the installation of winter pansies as well as spring blooming tulips.

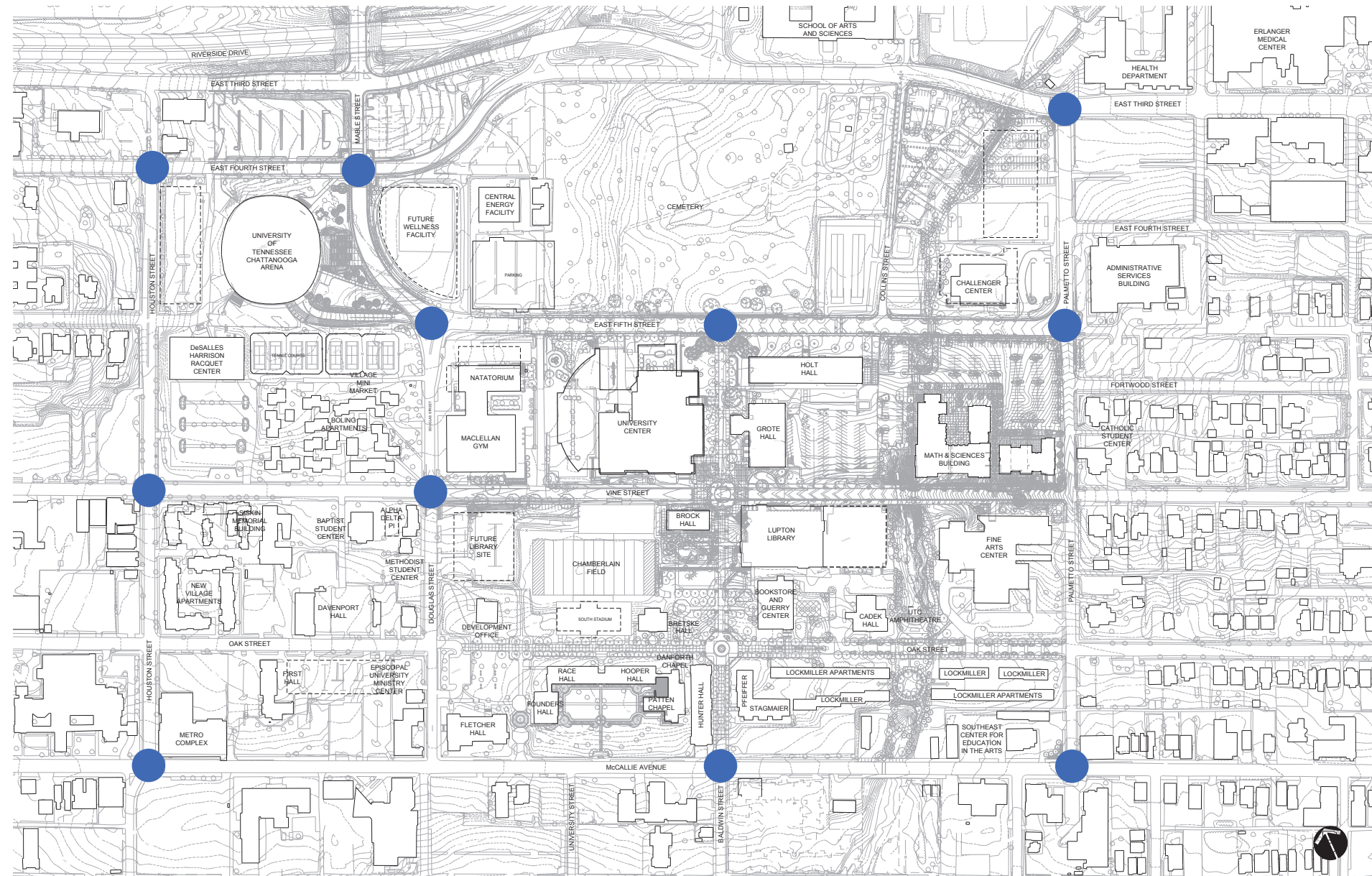

LOCATION PLAN

Part 16: Landscape Improvements

Soil testing will be required before any planting operations are begun. A licensed Landscape Architect will be retained for the design of Landscape Improvements.

16.07 Planting sizes:

New plant installation shall be in conformance with the following recommended sizes due to the scale and mature character of the campus.

- A. Shade trees – 4” caliper
- B. Street trees – 4” caliper
- C. Flowering trees – 3” caliper
- D. Evergreen trees – shall be branched to ground with minimum height of 8’
- E. Screen trees – shall be branched to ground with minimum height of 8’
- F. Shrubs – 3 gal. Or equivalent in balled and burlap
- G. Groundcovers – 2 ½” container
- H. Annuals – 2 ½” container
- I. The transition between lawn areas and planting beds shall be either a pre-fabricated metal, brick or stone edge.

16.08 Planting Periods:

- A. Planting for trees, shrubs, and groundcovers is recommended during the dormant season of November 15th through March 15th. Container plants can be planted year round if regularly irrigated.

- B. Installation of sod is recommended from March to December, but sod can be planted year round as long as it will be regularly irrigated.

C. Seeding:

- 1. Spring or Fall Seeding - Plant between March 15th and May 1st or between August 15th and October 15th.
- 2. Temporary Winter Seeding - Plant between October 15th and March 15th.
- 3. Temporary Summer Seeding - Plant between May 1st and August 15th.

16.09 Planting List:

The following plant material has been selected for their low maintenance and long life.

A. Groundcovers:

- 1. Hedera helix – English Ivy
- 2. Hypericum calycinum – St. John’s Wart
- 3. Liriope muscarii – ‘Big Blue’ Lily Turf
- 4. Ophiopogon japonicus – Mondo Grass
- 5. Pachysandra terminalis – Pachysandra
- 6. Vinca minor – Periwinkle
- 7. Vinca major - Periwinkle

B. Shrubs:

- 1. Ilex cornuta ‘Carissa’ – Carissa Holly
- 2. Ilex vomitoria ‘Nana’ – Dwarf Yaupon
- 3. Prunus laurocerasus ‘Otto Luyken’ – Otto Luyken Laurel
- 4. Buxus sempervirens – Boxwood
- 5. Viburnum Rhytidophyllum – Leather leaf Viburnum
- 6. Taxus baccata ‘Repandens’ – English Yew
- 7. Taxus x media ‘Densiformis’ – Densiformis Yew

- 8. Ilex aquifolium – English Holly
- 9. Ilex cornuta ‘Burfordii’ – Burford Holly
- 10. Ilex latifolia – Lusterleaf Holly
- 11. Myrica cerifera – Wax Myrtle
- 12. Prunus laurocerasus ‘Magnolifolia’ – English Laurel
- 13. Taxus x media ‘Hicksii’ – Hicks Yew
- 14. Prunus caroliniana – Cherry Laurel
- 15. Prunus laurocerasus ‘Schipkaensis’ – Schipkaensis Laurel

C. Flowering shrubs:

- 1. Hydrangea species – Hydrangea
- 2. Jasminum floridum – Showy Jasmine
- 3. Jasminum rufeflorum – Winter Jasmine
- 4. Pieris japonica – Pieris
- 5. Rhododendron species – Azalea & Rhododendron
- 6. Kalmia latifolia – Mountain Laurel
- 7. Hydrangea quercifolia – Oakleaf Hydrangea
- 8. Nandina domestica – Heavenly Bamboo

D. Evergreen and Screen Trees:

- Magnolia
- 1. Virginiana – Sweetbay Magnolia
- 2. Tsuga canadensis – Hemlock
- 3. Cedrus deodara – Deodar Cedar
- 4. Ilex x attenuata – Foster’s Holly
- 5. Ilex opaca – American Holly
- 6. Ilex ‘Nellie R. Stevens’ – Nellie R. Stevens Holly
- 7. Ilex x ‘Emily Bruner’ – Emily Bruner Holly

E. Lawn Trees:

- 1. Cercidiphyllum japonicum – Katsura Tree
- 2. Quercus palustris – Pin Oak
- 3. Liriodendron tulipifera – Tulip Poplar
- 4. Fagus grandifolia – American Beech
- 5. Fagus sylvatica – European Beech
- 6. Quercus phellos – Willow Oak
- 7. Quercus nigra – Water Oak

- 8. Liquidambar styraciflua ‘Rotundiloba’ – Sweetgum
- 9. Acer saccharum – Sugar Maple
- 10. Acer rubrum – Red Maple
- 11. Aesculus x carnea – Red Horsechestnut
- 12. Aesculus octandra – Yellow Buckeye
- 13. Betula nigra ‘Heritage’ – River Birch
- 14. Carpinus betulus – American Hornbeam
- 15. Carya ovata ‘Shagbark Hickory’ – Shagbark Hickory
- 16. Ginkgo biloba ‘Autum Gold’ – Ginkgo
- 17. Gymnocladus dioica – Kentucky Coffee tree
- 18. Magnolia acuminata – Cucumber tree Magnolia
- 19. Nyssa sylvatica – Black Tupelo
- 20. Plantanus occidentalis – American Sycamore
- 21. Quercus alba – White Oak
- 22. Quercus macrocarpa – Bur Oak
- 23. Quercus hemisphaerica – Darlington Oak
- 24. Quercus acatissima – Sawtooth Oak
- 25. Quercus imbricaria – Shingle Oak
- 26. Quercus coccinea – Scarlet Oak
- 27. Quercus robur – English Oak
- 28. Tilia cordata – Littleleaf Linden

Part 16: Landscape Improvements

16.09 Planting List (Continued):

F. Columnar Trees

1. Acer Saccharum ‘Endowment’ - Sugar Maple
2. Acer Saccharum ‘Goldspire’ - Sugar Maple
3. Acer Saccharum ‘Greencolumn’ - Sugar Maple
4. Acer Saccharum ‘Appollo’ - Sugar Maple
5. Acer Saccharum ‘Lanco Columnar’ - Sugar Maple
6. Acer Saccharum ‘Newton Sentry’ - Sugar Maple
7. Acer Saccharum ‘Temple’s Upright’ - Sugar Maple
8. Acer Rubrum ‘Armstrong’ - Red Maple
9. Acer Rubrum ‘Autumn Spire’ - Red Maple
10. Acer Rubrum ‘Bowhall’ - Red Maple
11. Acer Rubrum ‘Columnare’ - Red Maple
12. Acer Rubrum ‘Red Rocket’ - Red Maple
13. Acer Rubrum ‘Scarlet Knight’ - Red Maple
14. Carpinus betulus ‘Columnaris’ - European Hornbeam
15. Carpinus betulus ‘Fastigiata’ - European Hornbeam
16. Carpinus betulus ‘Franz Fontaine’ - European Hornbeam
17. Magnolia Grandiflora ‘Hasse’ - Southern Magnolia
18. Magnolia Grandiflora ‘Alta’ - Southern Magnolia
19. Quercus robur ‘Skyrocket’ - English Oak
20. Quercus robur ‘Regal Prince’ - English Oak
21. Quercus robur ‘Rosehill’ - English Oak

G. Street Trees:

1. Quercus phellos – Willow Oak
2. Quercus nigra – Water Oak
3. Liquidamber styraciflua ‘Rotundiloba’ – Sweetgum (fruitless)
4. Acer saccharum – Sugar Maple
5. Acer rubrum – Red Maple

H. Flowering and small scale Trees:

1. Cladrastis kentukea – Yellowwood
2. Cornus florida – Flowering Dogwood
3. Cornus kousa – Kousa Dogwood
4. Amelanchier species & hybrids – Serviceberry
5. Koelreuteria paniculata – Goldenrain tree
6. Magnolia x soulangiana – Saucer Magnolia
7. Magnolia stellata – Star Magnolia
8. Lagerstroemia indica – Crape Myrtle
9. Cercis canadensis – Redbud
10. Prunus x yedoensis – Yoshino Cherry
11. Crataegus viridus ‘Winter King’ – Winter King Hawthorn
12. Acer buergeranum – Trident Maple
13. Acer palmatum – Japanese Maple
14. Oxydendrum arboreum – Sourwood

I. Perennials:

- Ornamental grass is not recommended due to it’s requirement for high maintenance. The following are perennials that are acceptable:
1. Hosta
  2. Hemerocallis - Daylilly
  3. Lenton Rose

J. Turf:

1. Seeding - A 50/50 blend of Rebel Fescue and Falcon Fescue
2. Sodding - An approved nursery grown sod composed of a blend of 90% fescues plus 10% Kentucky Bluegrass

K. Bulbs:

1. Tulips
2. Daffodils

16.10 Irrigation:

- A. All new planting improvements shall be irrigated with an automatic irrigation system.
- B. The irrigation system shall be designed to provide 100% irrigation coverage for all tree, shrub, turf and seasonal color beds.
- C. Maintenance staff shall be trained in irrigation system maintenance and operation.

Part 17: Sculptures / Memorials

17.01 The addition of sculpture on campus shall be in conformance to the following standards:

- A. The use of sculpture shall be confined to a few visually prominent and higher impact locations on campus.
- B. Proposed sculpture and it's location shall be approved as to content prior to commissioning.
- C. Outdoor scale and the specific location of the sculpture shall be considered in the acquisition and or commission of any sculpture.
- D. Sculpture proposed for the campus shall be in one of the following categories:
  - 1. Sculpture which honors individuals or meaningful university events.
  - 2. Art form expression.
- E. Sculpture materials shall be maintenance free and long lasting.
- F. Memorials / Class gifts:
  - 1. Future memorials and class gifts shall be presented in the form of bronze plaques, brick or granite inscriptions attached to a specific vertical wall or paving element.
  - 2. Memorials and class gift contributions shall be acknowledged with plaques and the gift money shall be accumulated over time. Once the gift money has reached an appropriate level, significant gifts can be considered such as:
    - A. Clock towers
    - B. Significant sculpture
    - C. Specimen tree plantings
- G. High maintenance flower beds shall not be permitted.
- H. The addition of a large scale university seal is recommended as a sculptural element to the campus and shall be located in the ground plane and shall be constructed of a long lasting material such as stone.
- I. Honorary accreditation symbols are site / building specific and shall be designed and located on a project by project basis by the design professional. Specific elements should be located inside the building whenever possible.

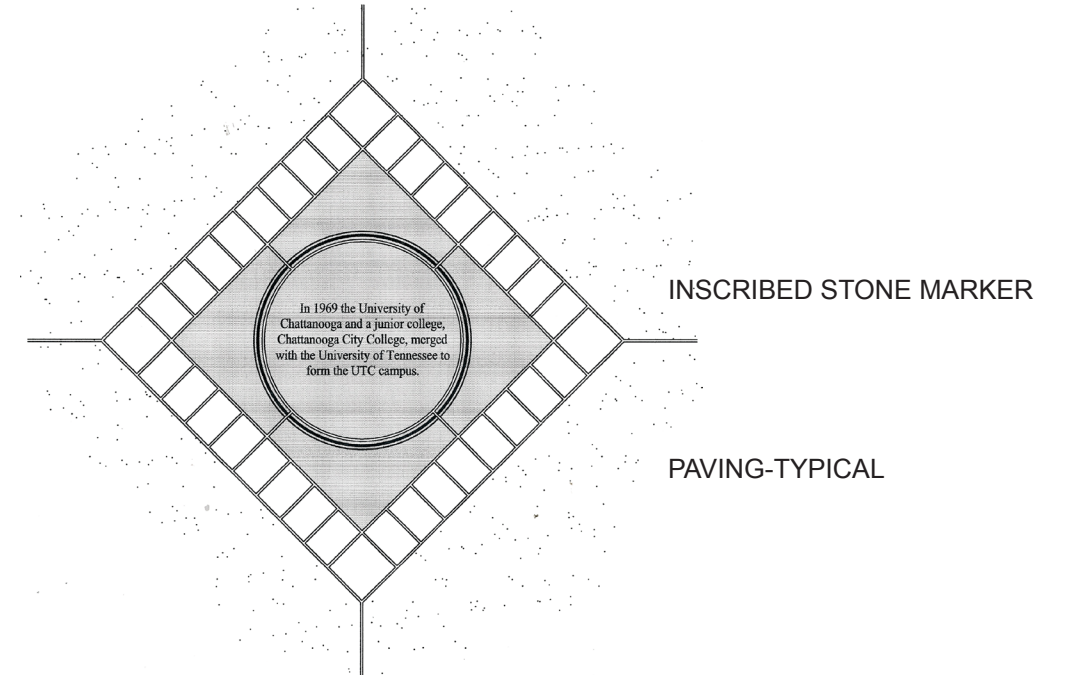

TYPICAL MARKER : GIFT, MEMORIAL, HONORARIUM, ETC.

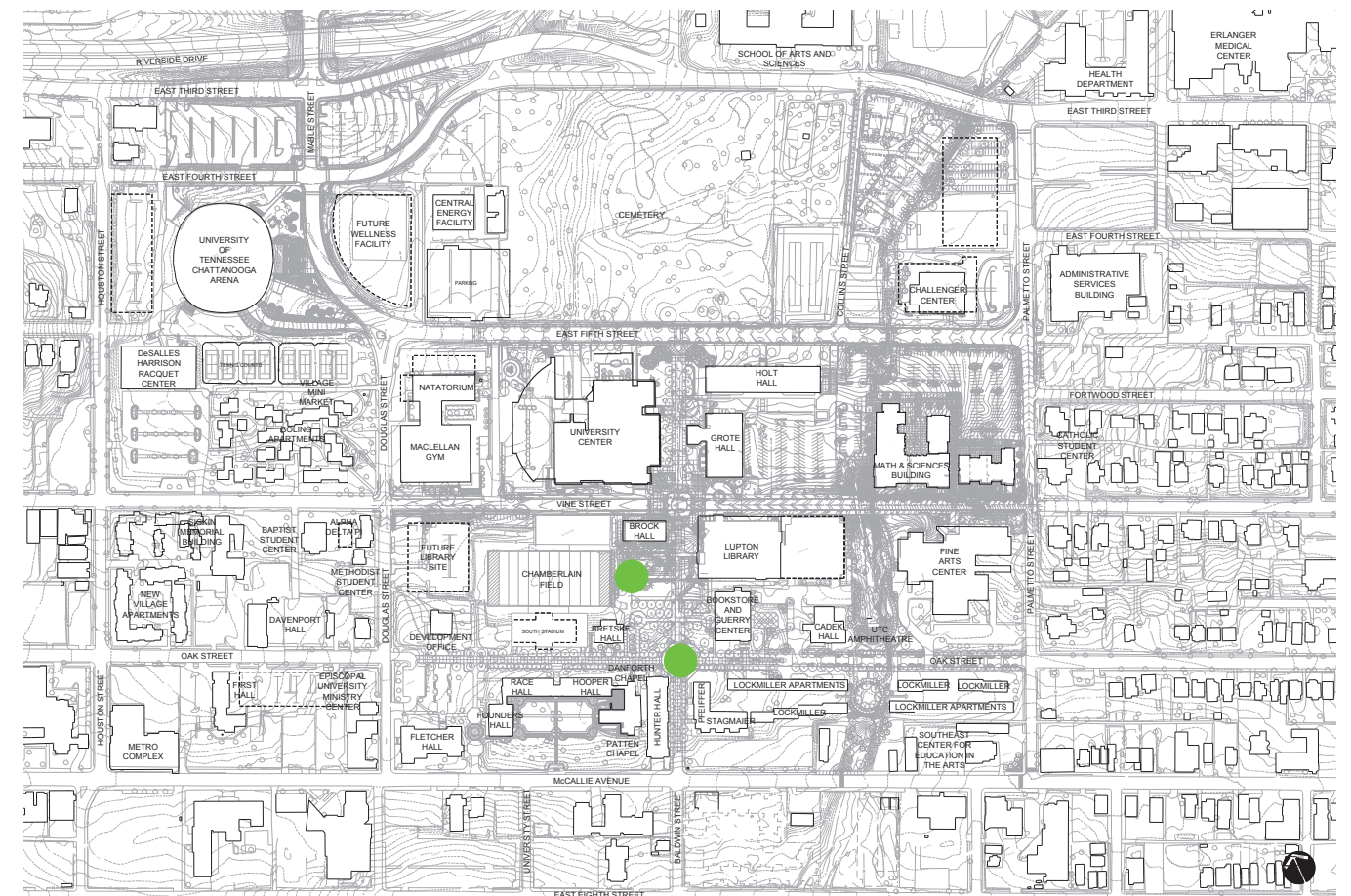

INITIAL SCULPTURE LOCATIONS

CAMPUS SITE IMPROVEMENTS

Part 18: Priority Projects

18.01 Pedestrian Mall:

Located in the heart of campus, the mall extends from East Fifth Street to McCallie Avenue. The mall includes a pedestrian drop off zone, fountain court, terraced lawns, sculpture plaza and pedestrian connection to McCallie Avenue.

18.02 Oak Street Improvements:

These improvements extend from Palmetto Street to Douglas Street. They incorporate new streetscape enhancements and vehicular turnaround on the eastern end of the street. The existing closed portion has been updated to provide a more pedestrian oriented space.

18.03 Vine Street Improvements:

These improvements extend from Palmetto Street to just east of Maclellan gym. They incorporate new streetscape enhancements and vehicular turnaround on the eastern end of the street. The existing closed portion has been updated to provide a pedestrian dominant space.

18.04 Fifth Street Improvements:

Fifth Street improvements extend from the intersection at Douglas Street eastward to Palmetto street. Enhancements shall include landscaped areas with street tree planting that will strengthen and define the major vehicular feeder into campus. City of Chattanooga's cooperation should be sought in development of Fifth Street improvements.

18.05 Douglas / Palmetto / Houston Street Improvements:

These streetscapes shall be enhanced with appropriate street tree planting to further define these important perimeter streets.

18.06 Campus Entry Improvements:

These improvements are located at four key portal positions. They include masonry wall identifiers with supporting landscape enhancements.

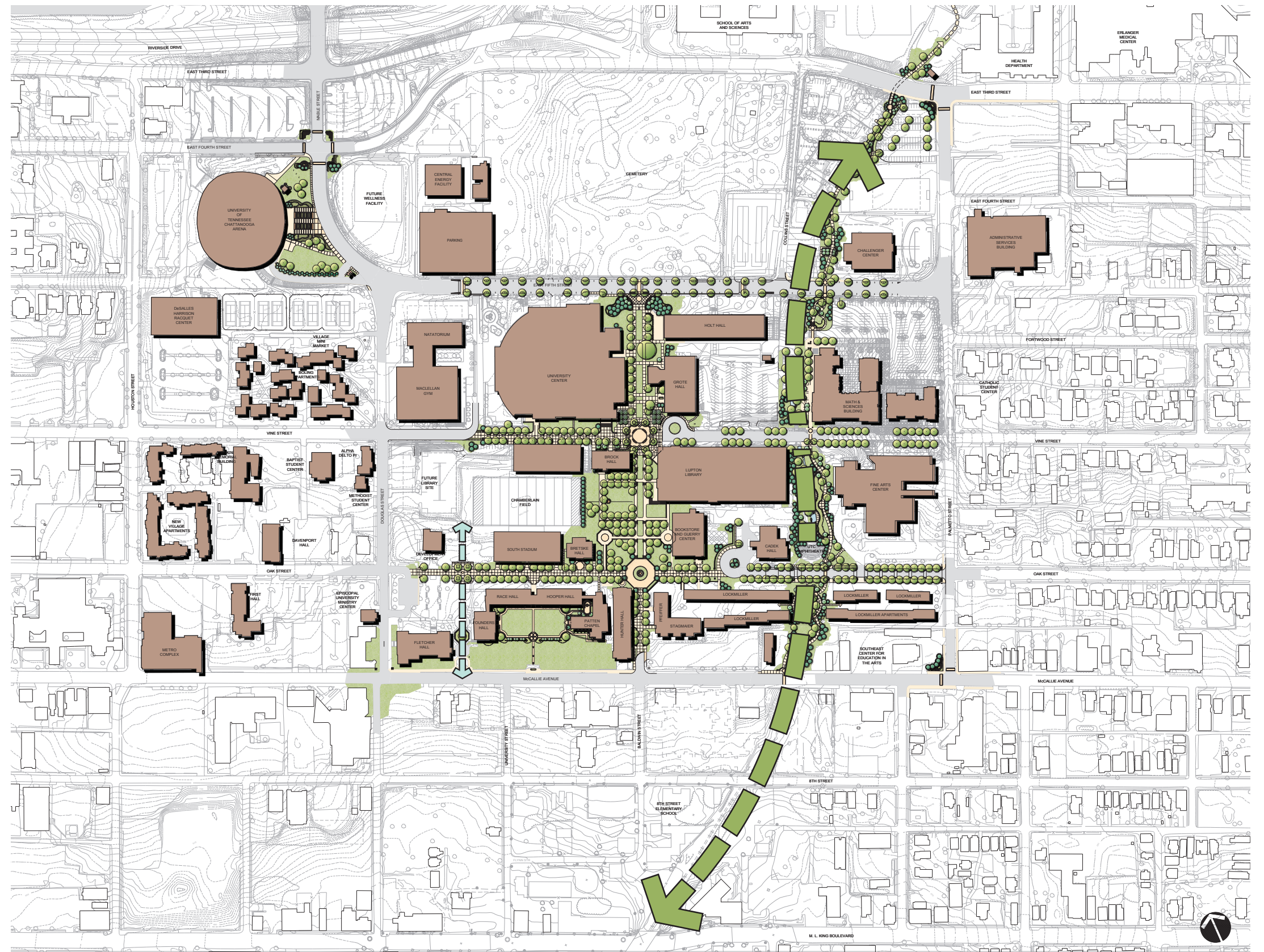

Part 18: Priority Projects

18.07 Founders Hall Quadrangle:

These improvements are proposed to enhance the historic position of this ceremonial pedestrian entrance to campus from McCallie Avenue. Enhancements include a lawn terrace, brick sidewalks, seating areas and updated landscapes and lighting.

18.08 McKenzie Arena Improvements:

The entrance to Gate 1 shall be enhanced with improved pedestrian lighting, brick seat walls, paving, landscaping and the incorporation of new monumental banner/light elements.

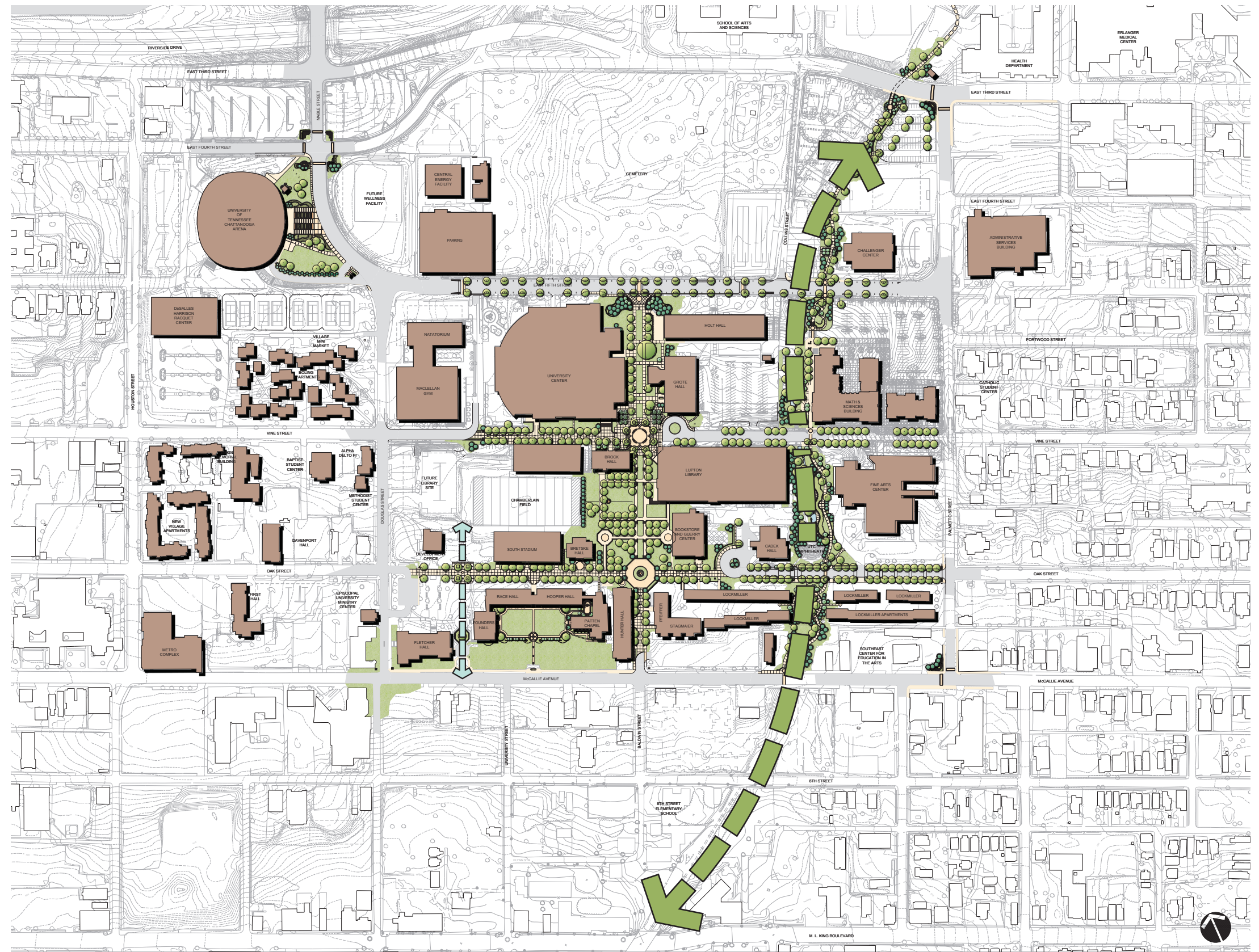

Part 19: Pedestrian Mall

19.01 The pedestrian mall improvements are designed to create strong pedestrian connections for students moving north and south through campus. The plan features the following design elements.

- A. Pedestrian drop off area at East Fifth Street.
- B. Masonry gateway elements and color beds at the north and south entrance.
- C. Large open lawn terraces.
- D. A fountain court at Vine Street with adjacent seating plazas.
- E. Two sculpture elements in prominent locations.
- F. Two smaller gathering / classroom spaces.
- G. Granite insets in pavement.
- H. Numerous seatwalls.
- I. Updated site furnishings.
- J. Special utility connections shall be incorporated for outdoor activities.
- K. Redesign of existing student park adjacent to Brock Hall to resolve ADA issues and to conform with design guidelines.
- L. Emergency and service access shall be provided.

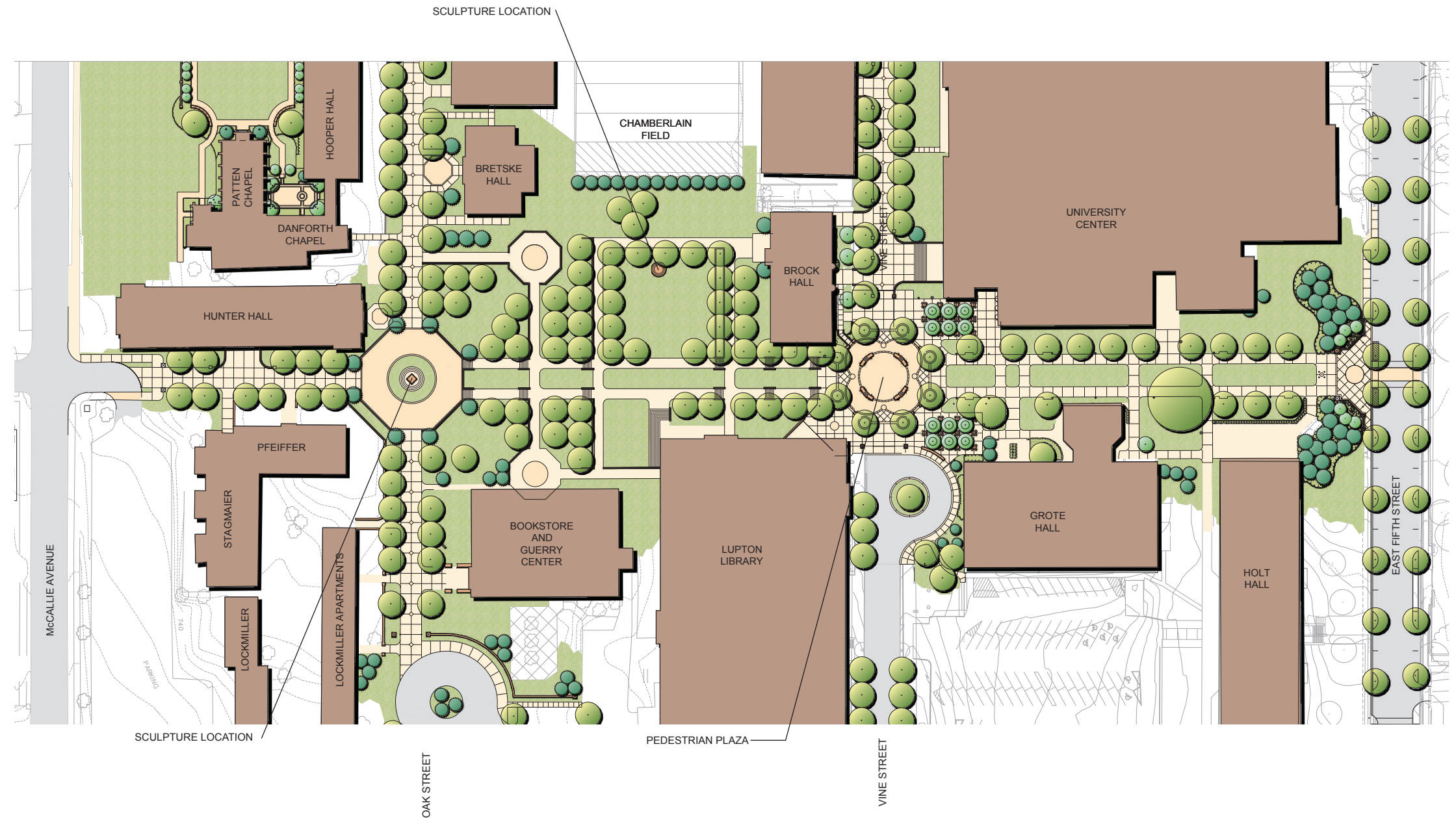



Part 20: Vine Street Improvements

20.01 The Vine Street Improvements are designed to create a strong pedestrian environment. The plan features the following design elements:

- A. Street tree planting.
- B. Small scale tree planting in Bump-outs.
- C. Pedestrian drop-off at Library.
- D. New pedestrian paving on the western end.
- E. Two entry features with associated seasonal color.
- F. Granite insets in pavement.
- G. Updated site furnishing.
- H. Informal mix of pedestrian and bicycle movement.
- I. Vehicular turnaround shall be sized to accommodate city buses.
- J. On grade pedestrian crossing at future greenway.
- K. Emergency and service access shall be provided.

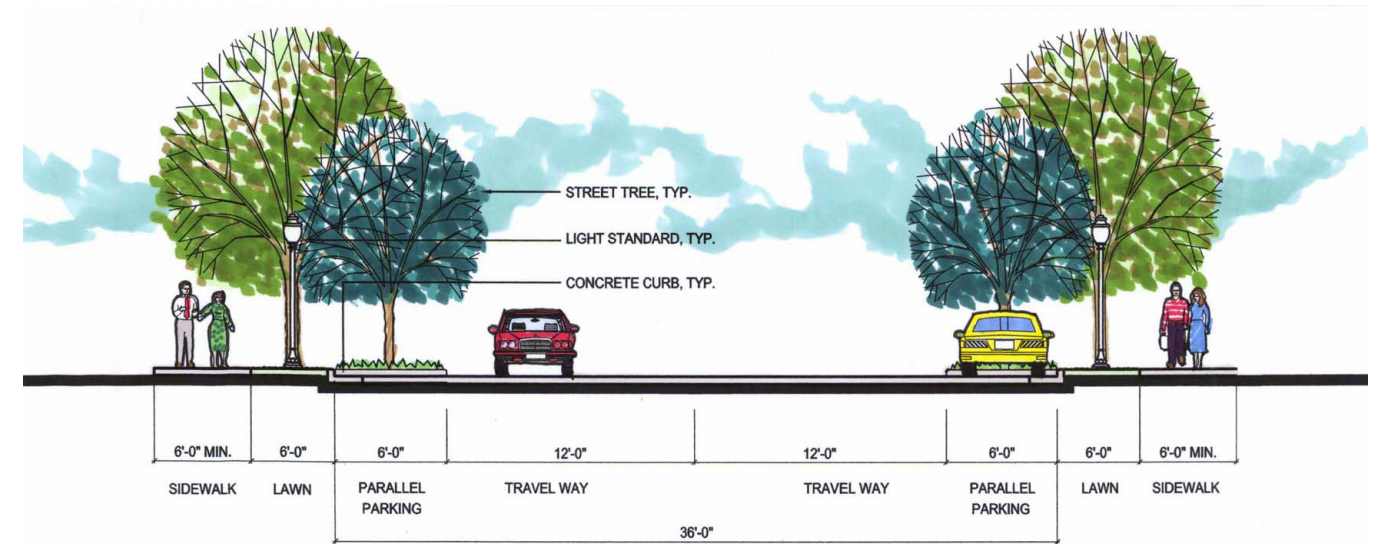

VINE STREET

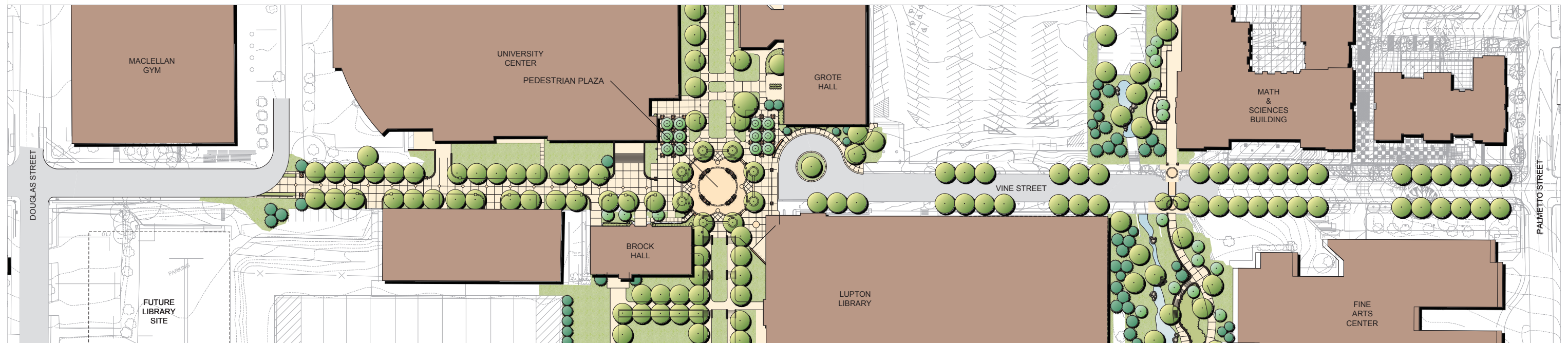

Part 21: Oak Street Improvement

21.01 The Oak Street improvements are designed to create a strong pedestrian environment. The plan features the following design elements:

- A. Street tree planting.
- B. Small scale tree planting in bump-outs.
- C. Pedestrian drop-off and handicap parking available at the eastern section.
- D. Two entry features.
- E. Granite insets in pavement.
- F. Updated site furnishings.
- G. Masonry seatwalls.
- H. Informal mix of pedestrian and bicycle movement.
- I. Vehicular turnaround shall be sized to accommodate city buses.
- J. On grade pedestrian crossing at future greenway.
- K. Emergency and service access shall be provided.

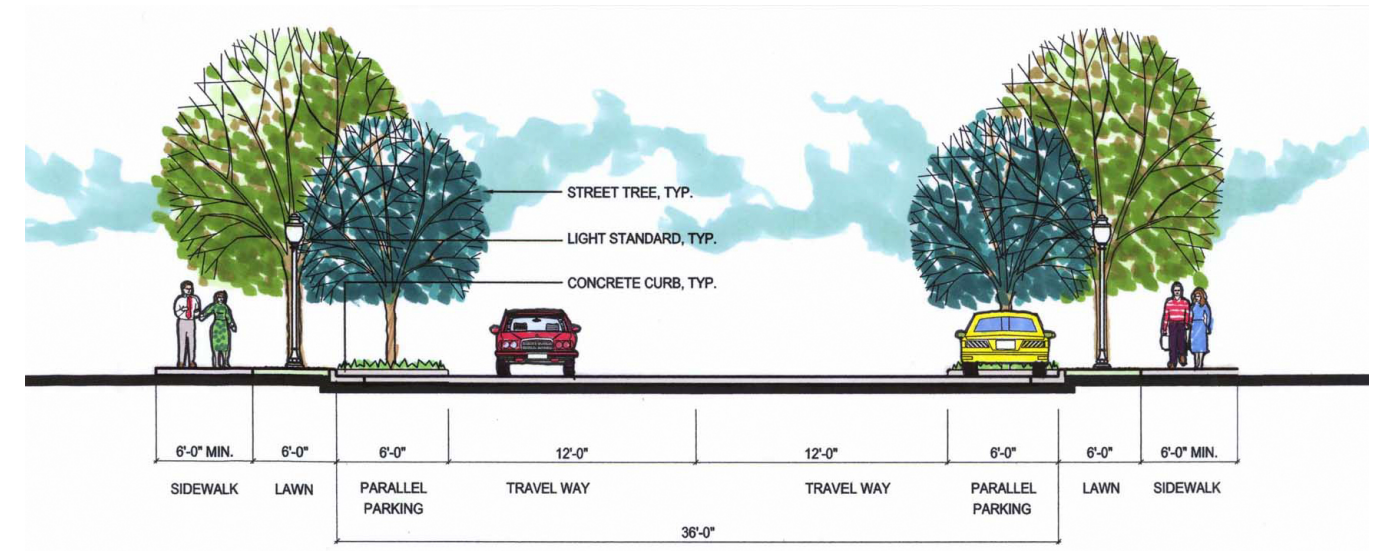

OAK STREET

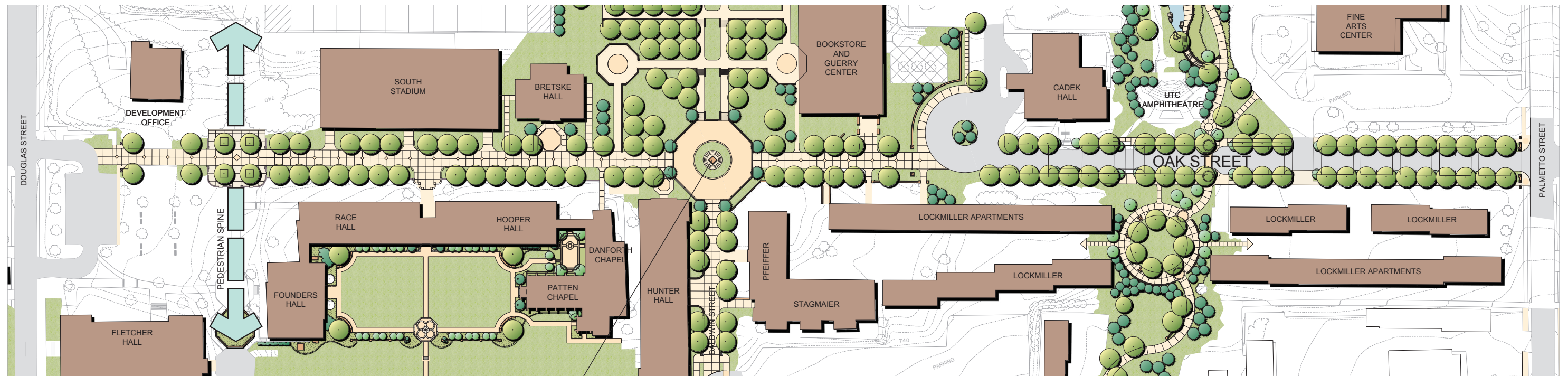

SCULPTURE LOCATION

Part 22: Campus Gateways

22.01 The campus gateway improvements are designed to identify the edges of campus and to create a strong sense of arrival. The plan features the following design elements:

- 22.02 East Fourth Street / Mabel Street
  - A. Masonry entry portal with the University identifier
  - B. Evergreen backdrop
  - C. Shrub foreground planting
  - D. Seasonal color beds
- 22.03 Palmetto Street / East Third Street
  - A. McCallie Avenue / Palmetto Street
  - B. Masonry entry portal with the University identifier
  - C. Evergreen backdrop
  - D. Shrub foreground planting
  - E. Seasonal color beds
- 22.04 Douglas Street / McCallie Avenue
  - Masonry entry pilasters



MABEL ENTRY AT EAST FOURTH

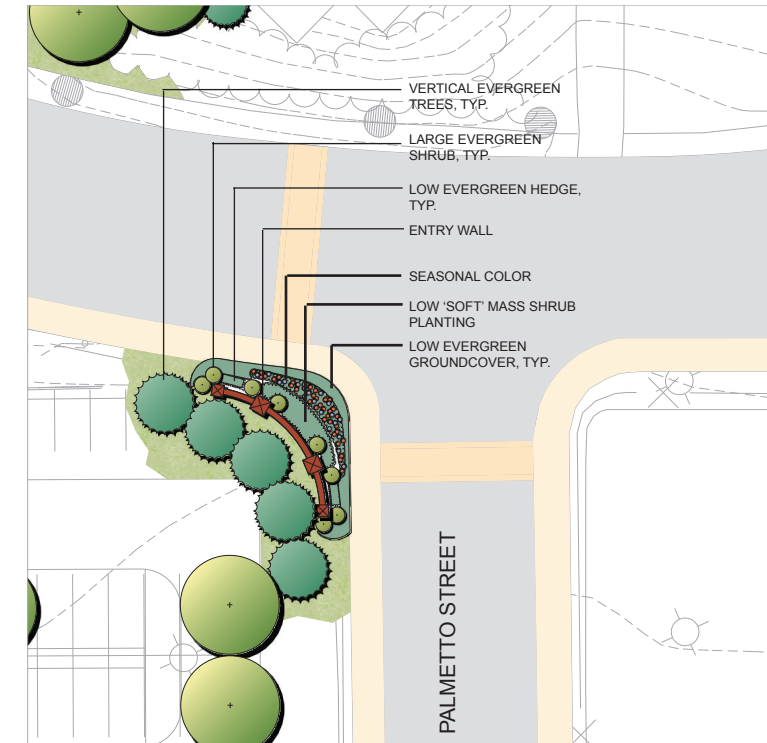

PALMETTO ENTRY AT EAST THIRD

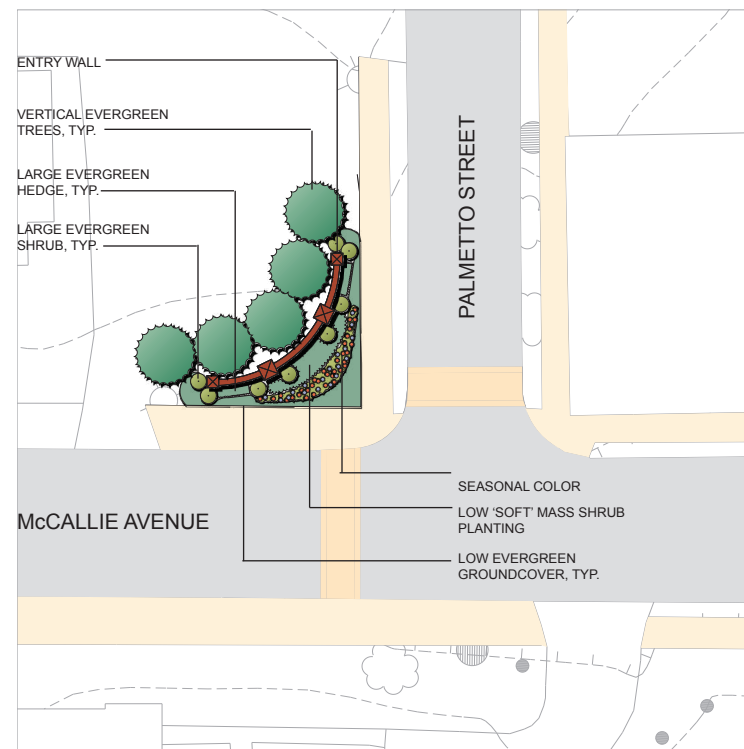

PALMETTO ENTRY AT McCALLIE

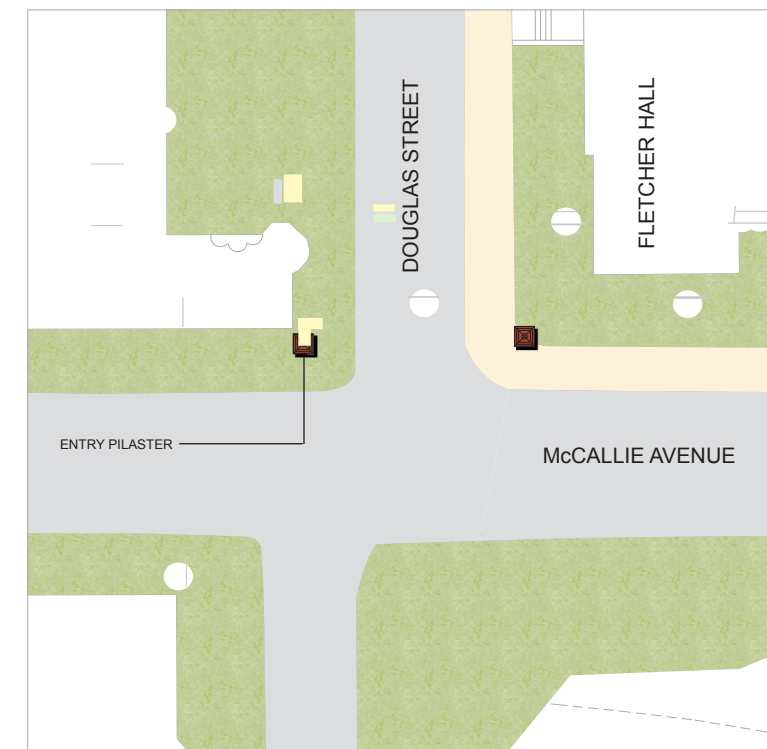

DOUGLAS ENTRY AT McCALLIE

Part 23: Greenway Access Points

There are four on-grade greenway crossings through the campus and they are as follows:

- 23.01 McCallie Avenue
- 23.02 Oak Street
- 23.03 Vine Street
- 23.04 Fifth Street



McCALLIE AVENUE



OAK STREET



VINE STREET

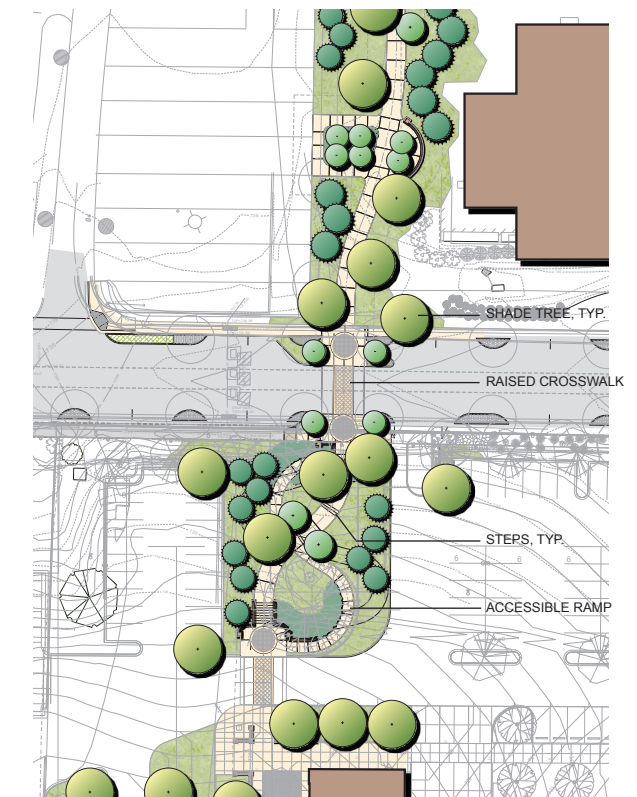

5th STREET

Part 24: Founder Hall  
Quadrangle

24.01 The Founders Hall improvements are designed to improve and enhance this prominent entrance to campus. The plan features the following:

- A. Enhancement of the existing pedestrian entrance off McCallie
- B. Brick sidewalks and steps
- C. Terrace site wall w/ Ballustrade
- D. New plaza at Flagpole
- E. Masonry seat walls
- F. Sidewalk connections to Patten Chapel
- G. Axial lawn terrace
- H. Enhanced shrub and tree planting



Part 25: McKenzie Arena

25.01 The improvements to Gate 1 of McKenzie Arena are designed to increase visibility and create a strong sense of entry to the building. The design proposal includes:

- A. Updated concrete pavement and steps
- B. Masonry seat walls
- C. Integrated pedestrian bollard lighting
- D. Enhanced massed shrub and tree plantings
- E. Feature color planting beds
- F. New banner/lighted focal entrance identification elements
- G. Security/fencing upgrades
- H. Drainage improvements

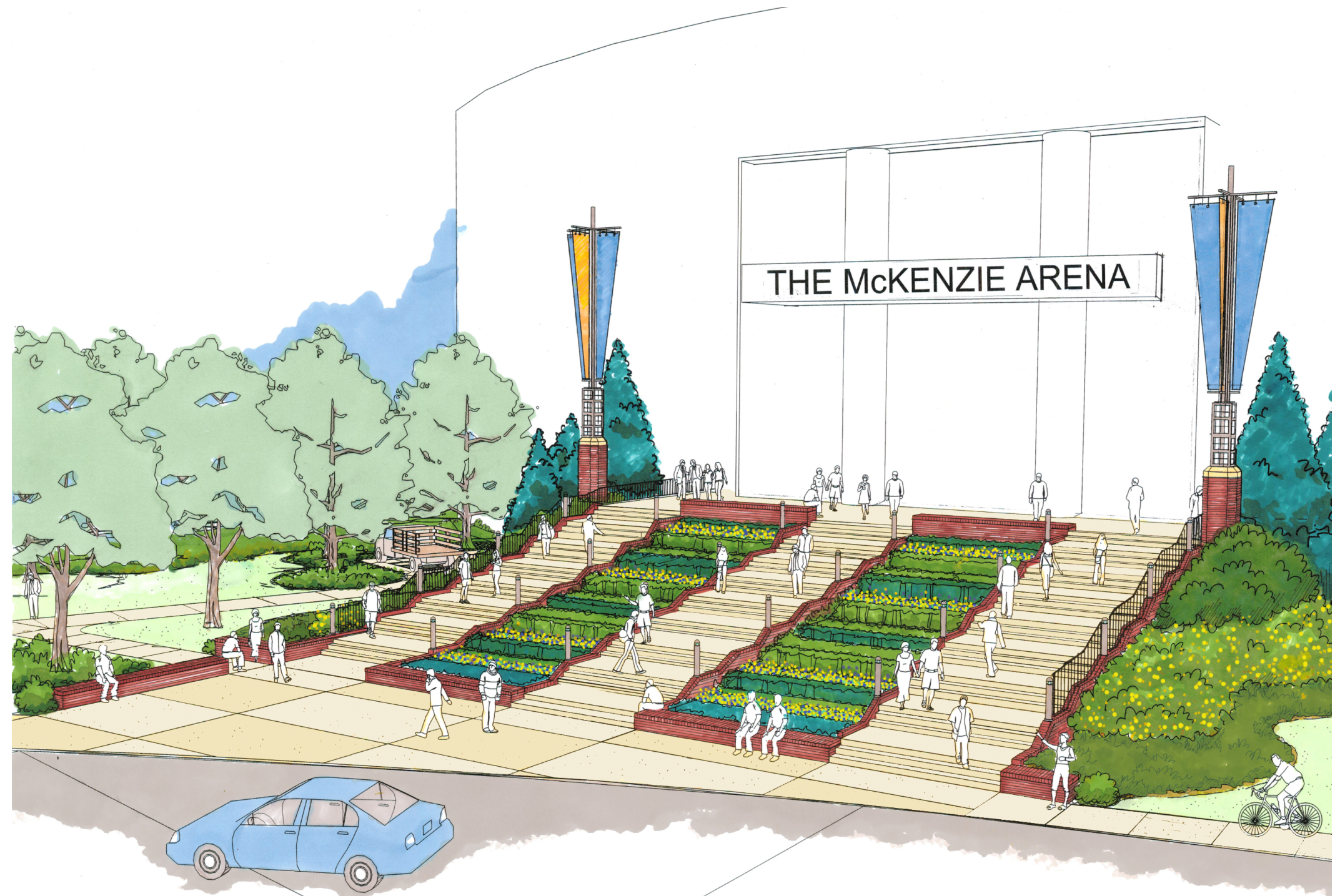

PERSPECTIVE VIEW  
SCALE: N.T.S.



## Part 26: Summary Recommendations

26.01 The Landscape Design Guideline recommendations are organized into three major categories: priority projects, hardscape / landscape improvements and landscape maintenance. These recommendations define major project goals and objectives by addressing the following: site improvements, streetscape improvements, site furnishings, pedestrian circulation, parking, open space, landscape, landscape maintenance, accessibility issues and utility relocations.

### 26.02 Priority Projects

- A. Pedestrian Mall
- B. Oak Street Improvements
- C. Vine Street Improvements
- D. Fifth Street Improvements
- E. Douglas / Palmetto / Houston Street Improvements
- F. Campus Entry Improvements
- G. Founders Hall Improvements
- H. McKenzie Arena Improvements

### 26.03 Hardscape and landscape improvements:

- A. Pave existing gravel parking lots and incorporate landscape and lighting improvements.
- B. In areas not already identified as a priority project, replace existing hardscape, site furniture, signage and lighting with approved standards as needed.
- C. Building and site capital improvements shall budget and incorporate the construction of improvements such as paving, walls, site furnishings, lighting, irrigation, landscape and underground utilities. Accessibility issues shall be addressed with the construction of these projects.

### 26.04 Landscape Maintenance:

- A. Retain a qualified professional to prepare a comprehensive tree inventory and make specific recommendations regarding a program of long term care, including watering, fertilization, pest and disease management, and pruning.
- B. Replace short lived, diseased, and/or declining campus trees with long lived legacy trees.
- C. Remove high maintenance gardenesque plantings from all areas except those identified as focal points and replace with plantings from the approved plant list.
- D. Retain a qualified professional to prepare a comprehensive lawn inventory and make specific recommendations regarding a program of long term care, including irrigating, fertilization, disease control, and cutting.
- E. Incorporate automatic irrigation system into all major capital improvement projects.
- F. Seek to provide irrigation to all major landscape areas of campus.